

Ikelite EV-Controller

i n s t r u c t i o n m a n u a l

#4100.6



Ikelite's EV-Controller is a manual exposure controller for Ikelite DS Substrobes exclusively. The controller provides 10 manual power settings in half-stop increments for maximum versatility and control of the flash exposure.

Please familiarize yourself with the features and functions of the system before trying the camera and strobes in the water.

BASICS

- The EV-Controller is compatible **ONLY** with Ikelite DS Substrobes.
- Set the strobe in the TTL full-power setting.
- Adjust the EV Selector Dial on the EV Controller to manually set the strobe output in half-stop increments.
- The EV-Controller is automatically turned on and off as the strobe is turned on and off.
- No battery is required in the EV-Controller as the strobe powers the controller. The power drain on the strobe is negligible.
- The EV-Controller features a built-in slave sensor allowing the controller to be triggered by the flash from another strobe, or a sync cord can be connected to trigger the controller.
- Reference the visual ready light on the strobe for indication when the strobe has recycled and is ready to fire. There is no ready light indicator on the EV-Controller.
- For balanced lighting between your subject and the background, meter the available light and set the camera aperture accordingly.

3

FEATURES

- **EV Selector Dial:** 10-manual power settings adjust the strobe output in half-stop increments.
- **Switch Cap:** waterproof cover conceals separate camera and strobe selection switches.
- **Bulkhead Connector and Cap:** remove the waterproof cap to connect an optional sync cord.
- **Strobe Cord:** permanent cord connects EV-Controller to DS Substrobe.
- **External Black Cover (not shown):** protects the front of the EV-Controller. Remove the black cover to expose the built-in slave sensor.
- **Clamp Mount (not shown):** secures EV-Controller to stem mount on Ikelite arm system.

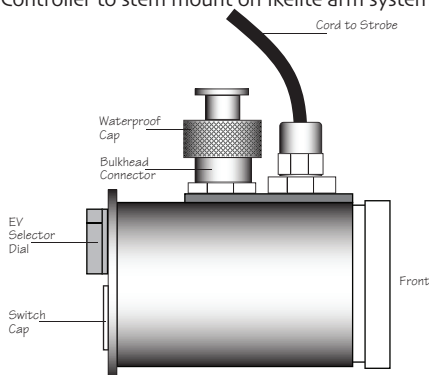

2

SELECTOR SWITCHES

The EV-Controller features two selector switches (camera P-⊕ and strobe 125-50) concealed behind the removable switch cap located on the back of the controller. Set each switch in the appropriate position.

Opening the Switch Compartment

Make sure the EV-Controller is dry before opening the selector switch compartment. Use a coin to unscrew the switch cover counter clockwise. Note the position of the o-ring around the perimeter of the cover. Keep the o-ring and sealing surfaces clean. Lightly lubricate the o-ring with silicone lubricant provided. Never use spray lubricant as it may crack the plastic.

After adjusting both camera and strobe selector switches, use a coin to secure the cover and hand-tighten to assure the proper o-ring seal.

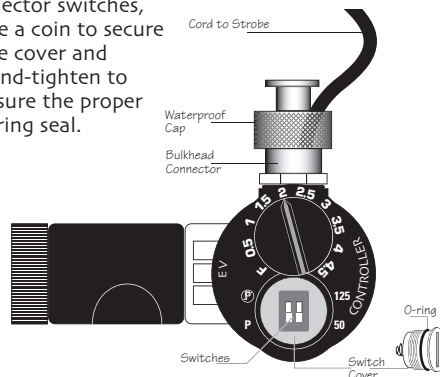

4

CAMERA SELECTOR SWITCH P \emptyset P

Set the camera switch to indicate whether preflash is present. A separate camera information sheet states whether or not each camera features preflash.

\emptyset - No preflash

This "no preflash" setting instructs the slave sensor to trigger the strobe every time it senses the other flash firing. Choose the "A-no preflash" setting when using an optional sync cord.

P - Preflash camera

This "preflash" setting instructs the slave sensor to ignore the first flash (preflash) and to trigger the strobe when the second flash (main flash) fires from the other strobe. The sensor will reset if no second flash is detected.

STROBE SELECTOR SWITCH 125-50

Set the strobe switch to indicate which strobe is connected to the EV-Controller.

Use 125 setting for DS125 & DS200 Substrobes.

Use 50 setting for DS50 & DS51 Substrobes.

EV-Controller is automatically turned on and off as the strobe is turned on and off.

5

TRIGGERING THE CONTROLLER Via Built-in Slave Sensor

- Remove the external black cover from the front of the controller to expose the slave sensor.
- Secure the controller to the stem mount at the base of the Ikelite strobe arm, and connect the cord from the controller to the strobe. See separate sections for more information.
- Aim the controller towards the triggering light source, which will be either the camera's built-in strobe or a separate auxiliary strobe. It makes no difference which light source is selected.
- When the slave sensor in the controller detects the other strobe firing, it fires the connected strobe at the exposure power setting you set on the controller.

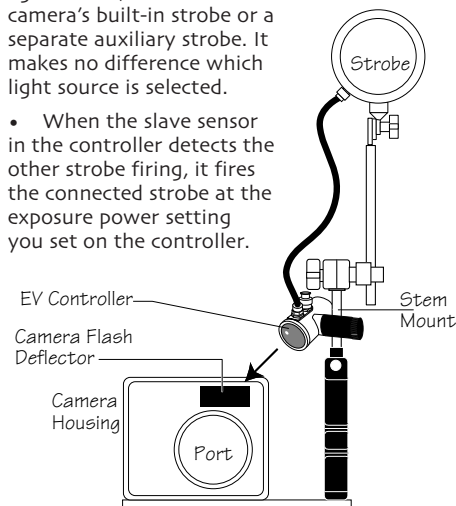

6

TRIGGERING THE CONTROLLER Via Optional Sync Cord

- Keep the black cover positioned over the front of the controller to disable the sensor.
- Secure the controller to the stem mount at the base of the Ikelite strobe arm, and connect the cord from the controller to the strobe. See separate sections for more information.
- Remove the waterproof cap from the controller and connect the optional sync cord from the camera system. See separate section.
- It is not necessary to aim the controller provided that the optional sync cord is connected and the slave sensor remains blocked.
- The controller fires the connected strobe when the camera shutter button is depressed.

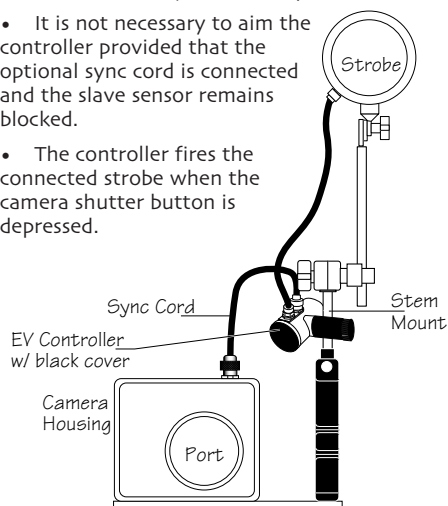

7

Choose from the following sync cords:

- #4103.51 connects one controller to Ikelite housing
- #4103.52 connects two controllers to Ikelite housing
- #4104.6 connects one controller to Nikonos style socket on another brand housing
- #4104.62 connects two controllers to Nikonos style socket on another brand housing

SETTING THE EV-CONTROLLER

It may take a few test shots to become familiar with the use of the EV-Controller. Use the EV Selector Dial on the controller to increase or decrease the flash exposure.

Visual Evaluation

With a digital camera, one may choose to evaluate the exposure of the subject on the camera's LCD screen and adjust the power setting of the EV-Controller based on that visual exposure evaluation.

Guide Number

The alternative method in adjusting the EV-Controller is to determine the power setting mathematically based on camera aperture and subject distance.

Multiply the camera aperture (f-stop) by the camera-to-subject distance, and the resulting value is the underwater guide number used to reference the suggested EV (exposure value) setting for the controller. Note that the chart is based on a camera set to ISO 100.

continued on next page

8

Guide Number Example:

Using the DS50/51 strobe with the camera's ISO set to 100. If the camera's aperture (f-stop) is set to f-3 and the subject distance is 4 feet, then the aperture of 3 multiplied times the distance of 4 equals a guide number of 12. In the chart under DS50/51 in the (ft) column, find guide number 12. The recommended EV setting would be "-2.5".

MOUNTING

The EV-Controller clamps to the stem mount at the base of the Ikelite strobe arm. This is the same stem mount that snaps into the quick release handle secured to the camera housing.

Position the controller with the cord pointing up. Loosen the mounting knob on the controller by rotating it counter-clockwise, and insert the stem mount of the arm thru the clamp opening on the controller.

The controller can move up and down and also rotate 360° to properly position before tightening the knob to secure the controller.

EV-CONTROLLER CHART

EV Controller Chart				
EV Settings	DS50/51		DS125/160	
	Guide # (UW) ISO 100		Guide # (UW) ISO 100	
	ft	m	ft	m
Full	28	9	32	10.2
-0.5	24	7	27	8.7
-1.0	20	6.5	22	7
-1.5	16	5	18	5.8
-2.0	14	4.5	16	5
-2.5	12	3.8	13	4
-3.0	9	2.8	11	3.5
-3.5	6	1.9	9	2.8
-4.0	4	1.2	7	2.2
-4.5	3	0.9	6	1.9

CORD CONNECTION TO STROBE

The short cord extending from the EV-Controller connects to the female bulkhead connector on the Ikelite DS Substrobe. This short cord is NOT removable from the controller.

DO NOT use the controller with other model Ikelite TTL Substrobes or another brand strobe.

Connecting the Strobe and Controller

The connector threads are very fine; **DO NOT** cross thread. If it is difficult to turn, you are cross threading.

1. Turn the Substrobe OFF and make sure all components are dry. Clean and lightly lubricate the stem o-ring and the bulkhead connector threads. Check o-ring for nicks or cuts. Never use spray lubricant.
2. Note the positioning of the receptacles and pins. Properly align the end of the cord on the controller and insert into the bulkhead connector.
3. Hand-tighten the knurled retaining ring on the cord. Push the connector body further into the bulkhead connector and continue to tighten the knurled ring to secure the cord.

DO NOT remove the cord from the strobe underwater or when wet. Connection is NOT waterproof when disconnected.

DO NOT leave the cord connected for prolonged periods. Otherwise, the cord may freeze to the strobe. After each dive, disconnect the cord and lightly lubricate the connector threads.

Never use spray lubricant.

BULKHEAD CONNECTOR

The EV-Controller features a female Ikelite bulkhead connector, which is sealed by a removable waterproof cap.

This bulkhead connector permits different Ikelite sync cords to be connected between the EV-Controller and select camera systems. The optional sync cord relays the trigger signal when the camera shutter button is depressed. Note that the camera housing **MUST** feature an Ikelite or Nikonos bulkhead connector to use the optional sync cord.

The removable waterproof cap seals the bulkhead connector on the controller when the optional cord is not used. The bulkhead connector must be sealed to remain waterproof.

Refer to the prior "Cord Connection" section of this instruction manual for the proper procedure to connect the optional cord.

DO NOT remove the optional cord from the controller underwater or when wet. Connection is NOT waterproof when disconnected.

DO NOT leave the cord connected for prolonged periods. Otherwise, the cord may freeze to the controller or camera system. After each dive, disconnect the cord and lightly lubricate the connector threads.

Never use spray lubricant.

TECHNIQUES

The purpose of a strobe is to illuminate the subject and bring out the subject's true colors. Due to the loss of color when light passes through water, move in on your subject to photograph thru as little water as possible. The maximum recommended lighting distance with ANY STROBE underwater is about 2m (6').

For balanced lighting between your subject and the background, meter the available light and set the camera aperture accordingly. A narrower aperture darkens the background. A wider aperture lightens the background.

ADD A SECOND STROBE

Avid photographers often add a second auxiliary strobe positioned away from the camera lens for more natural lighting. When using two strobes, choose an EV-Controller for each strobe to manually control both flash outputs.

To trigger the second strobe, use either the built-in slave sensor in the EV-Controller or connect an optional dual sync cord to both strobe/controller systems. The slave sensor in the controller enables the strobe to be moved freely and positioned virtually anywhere.

13

MAINTENANCE

The Ikelite EV-Controller should be given the same care and attention as your other photographic equipment.

1. Always rinse the exterior of the EV-Controller and Substrobe with fresh water after use. Make sure the cord is connected between the controller and strobe for the proper waterproof seal, and make sure the separate female bulkhead connector on the EV-Controller is sealed as well. The units can be cleaned by soaking them in a mild soapy solution. Use liquid soap; RINSE and DRY both before storage.
2. Keep the switch cover o-ring and threads clean and lightly lubricated. Keep the sync cord o-ring and threads clean and lightly lubricated. **DO NOT** leave the cord connected to the strobe for prolonged periods as electrolysis can make removal impossible.
3. With exception of the switch cover, the EV-Controller is factory sealed. **DO NOT** disassemble the controller.

LUBRICANT

Silicone lubricant is provided. Use only enough lubricant to lightly cover the o-ring; wipe off any excess with a clean cloth. Lubricant only reduces friction; it is NOT a sealant.

DO NOT use spray lubricant as it may crack the plastic.

15

VISUAL INSPECTIONS

Visual inspections are important. Take the time to visually inspect the system above water. An improper seal or a loose connection can cause a lot of damage. Always check for leaks once you place the system in the water.

INSURANCE

We recommend adding an ALL RISK floater to your homeowner's insurance policy in the event you damage, flood, or lose your camera or strobe. While the Ikelite EV-Controller has a limited warranty against manufacturing defects, it does not cover customer neglect.

BATTERIES

Always carry spare batteries. Weak batteries cause many camera and strobe problems. It is possible to buy bad "new" batteries; check the voltage output with a meter.

No battery is required in the EV-Controller. The DS Substrobe powers the EV-Controller, and the power drain on the strobe is negligible.

14

Ikelite Limited Warranty

This Ikelite product is warranted against any manufacturing defects for a period of two (2) years from the date of purchase. Defective products should be returned prepaid to Ikelite. Ikelite will, at its discretion, repair or replace such products, and will return to customer prepaid. All other claims, of any nature, including but not limited to bulb failure are not covered. Except as mentioned above, no other warranty expressed or implied, applies to this Ikelite product.

We recommend adding an ALL RISK floater to your homeowner's insurance policy in the event you damage, flood, or lose your camera or strobe. Ikelite warranty does NOT cover customer neglect.

Ikelite Underwater Systems

50 W 33rd Street
Indianapolis, IN 46208 USA

317-923-4523

email: ikelite@ikelite.com
www.ikelite.com

4100.6-03-1206