

IKELITE VIDEO CASE

SUPPLEMENTAL INSTRUCTIONS FOR

#6038.39 SONY DCR-DVD406, DVD408,
DVD506, DVD508, DVD808, DVD908

#6038.41 Sony DCR-DVD910, HDR-UX10, HDR-UX19, HDR-UX20

This supplemental set of instructions describes additional features specific to your housing model. Prior to testing the system in the water, please read this supplement along with the general instruction manual to become familiar with its features and functions.

Ikelite Video Cases are slightly negative in salt water for stability. This housing has been water pressure tested at the factory and has a working depth of 60m (200').

HOUSING CONTROLS

- Power On/Off / Mode
- Start/Stop
- Power Zoom
- Photo
- Easy
- Back Light

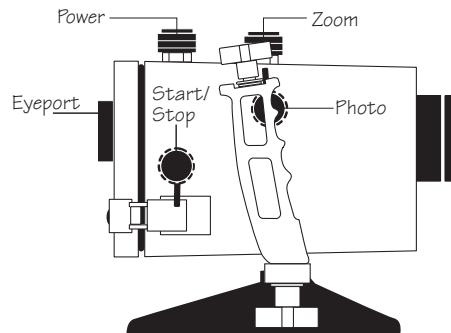
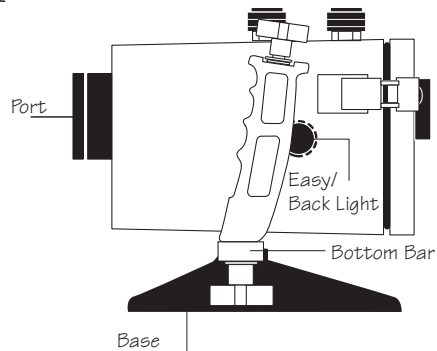

MAIN O-RING #0109

O-rings last several years if properly maintained. Control seals should not need to be replaced as long as the control shafts are kept clean and lightly lubricated.

PREPARATION

PACKAGED WITH HOUSING

- External UR/Pro Color Filter
- Silicone Lubricant
- Internal Lens Shade

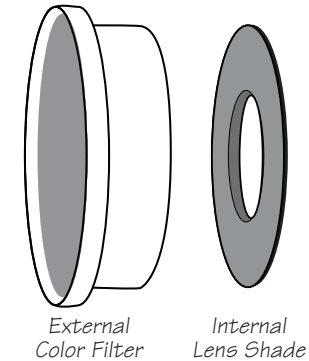

COLOR FILTER

The installation and usage of the external UR/Pro color filter is described in the general instruction manual.

LENS SHADE

The internal lens shade helps block light reflection/refraction caused by the interaction of the external color filter and the port.

Carefully thread the lens shade on the front of the camera lens. The lens threads are very fine; **DO NOT** cross thread. It should screw on very easily. If it is difficult to turn, you are cross threading.

Completely thread the lens shade into the camera to avoid any potential clearance or sealing problems when the camera is installed and the housing is sealed.

OPTIONAL WIDE ANGLE LENS

The housing's port accepts optional 67mm threaded waterproof Wide-Angle lenses such as the Ikelite #6420 W-20, Epoque DCL-20 and Inon UWL-100 Type 2 and Sea&Sea (58070). These waterproof lenses secure to the outside of the lens port.

Should you elect to use the optional Ikelite #6420 W-20, Epoque, Inon or Sea&Sea lens, carefully thread the waterproof lens on the front of the lens port. The lens threads are very fine; **DO NOT** cross thread. It should screw on very easily. If it is difficult to turn, you are cross threading.

INTERNAL WIDE-ANGLE LENS OPTION

Special ports are available for use with the Raynox HD-5050 Pro high definition wide-angle lens. optional ports sold separately as dome port #9304 or flat lens port #9304.1. Raynox HD-5050 Pro lens not included. Lens **not** available for purchase through Ikelite.

SUPER-EYE VIEWFINDER

See exactly what the camera sees underwater using the camera's electronic viewfinder in conjunction with the Ikelite Super-Eye, which is permanently mounted in the eyeport on the clear back plate. The Super-Eye extends the viewfinder image to provide enhanced viewing underwater.

LCD MONITOR

The camera's LCD monitor can be viewed thru the side of the housing. Open the LCD monitor on the camera, rotate 180°, and then press it back against the side of the camera so that the LCD monitor is visible.

To view the image on the LCD monitor from the rear of the housing, Ikelite offers optional External Mirror #9290.94, which adheres to the outside of the housing. Then the LCD image can be viewed from the rear.

BATTERY AND TAPE

Install a fully charged Sony battery on the camera:
Sony NP-FH50, NP-FH60, NP-FH70

Other brand batteries may not fit inside the housing. If the battery selected overhangs the camera tray by a dimension greater than 8mm (5/16"), then the battery is too large and will cause the housing to leak.

Make sure you have loaded an appropriate Sony disk in the camera.

FINAL PREPARATION

Remove the lens cap and cord from the camera. Otherwise, they may interfere with the housing seal.

The camera's auto focus feature is utilized underwater. For best results, move in close to your subject and use the wide-angle range to shoot thru as little water as possible. Full range zoom range is accessible underwater. Chart shows recommended initial settings underwater.

CAMERA	SETTING
Power On/Off	- Camera (On)
Zoom Lever	- Wide Angle Setting
Focus	- Auto Mode
Exposure	- Auto Mode
External Flash (if featured)	- Off

INSTALLATION

CAMERA TRAY

Note the placement of the camera tray underneath the guides, and note the two white-color locks on the inside wall of the housing that secure the tray in place. Gently push up on the white tray locks to release the camera tray, and slide the tray out of the housing.

Place the camera between the stabilizing pins on the tray. Secure camera with the tripod mounting bolt. The camera should fit easily on the tray and should be parallel with the sides of the tray.

Extend the camera's viewfinder to the rear position. The camera's viewfinder will be pushed forward slightly while remaining as close as possible to the Super-Eye on the back plate.

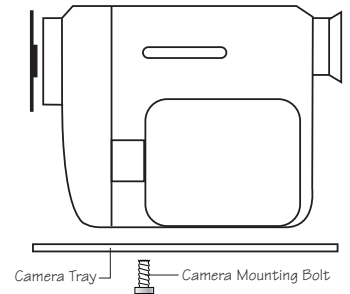

INSERTING THE CAMERA

Pull the housing controls out to provide clearance for the camera. Slowly slide the camera tray (with camera mounted) back into the housing.

DO NOT force this installation; if the controls are out of the way and everything is lined up properly, the camera and tray will fit easily inside. Make certain that the tray is completely in the housing, and make sure that both white tray locks have locked the camera tray in place.

HOUSING CONTROLS

Slide the housing controls back in place making sure they properly align with the camera functions.

Operate each control to see how it works with the camera. Some controls such as start/stop will be used frequently. Other controls may seldom be utilized. Refer to your camera owner's manual for the proper function of each camera control. Look thru the back to be sure that you can see into the viewfinder.

When using the housing controls, especially the start/stop, **DO NOT** use excessive force because you could damage the camera.

CAUTION

Remove the lens cap and cord from the camera. Otherwise, the cord may interfere with the housing seal. If the housing controls are not properly positioned, they could interfere with the housing seal.

IKELITE UNDERWATER SYSTEMS

50 West 33rd Street • PO Box 88100 • Indianapolis, IN 46208 USA • 317.923.4523
Email: ikelite@ikelite.com • www.ikelite.com