

# IKELITE VIDEO CASE

## SUPPLEMENTAL INSTRUCTIONS FOR

#6047 Canon ZR900, 930, 950  
MD200, 205, 215, 216, 235, 255



This supplemental set of instructions describes additional features specific to your housing model. Prior to testing the system in the water, please read this supplement along with the general instruction manual to become familiar with its features and functions.

Ikelite Video Cases are slightly negative in salt water for stability. This housing has been water pressure tested at the factory and has a working depth of 60m (200').

### HOUSING CONTROLS

- Power On/Off
- Start/Stop
- Power Zoom
- [P], Easy
- Function
- Joy Stick #1 - Focus, White Balance, Image Effect, Program AE & Digital Effect.
- Joy Stick #2
- Lens Switch

### MAIN O-RING #0109

O-rings last several years if properly maintained. Control seals should not need to be replaced as long as the control shafts are kept clean and lightly lubricated.

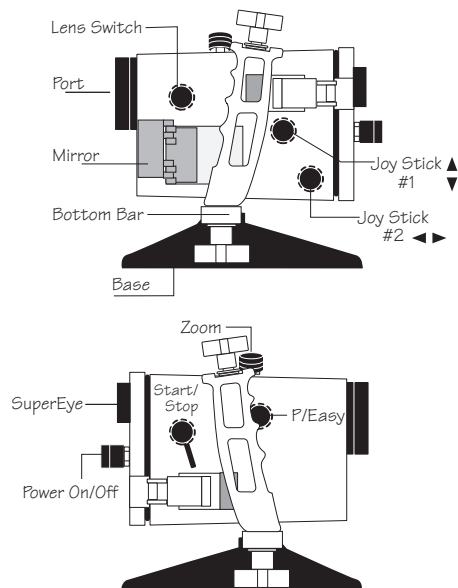

## PREPARATION

### PACKAGED WITH HOUSING

- External UR/Pro Color Filter
- Silicone Lubricant

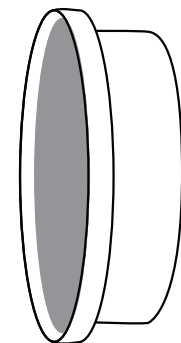

External Color Filter

### COLOR FILTER

The installation and usage of the external UR/Pro color filter is described in the general instruction manual.

### OPTIONAL WIDE ANGLE LENS

The lens port on the front of the housing accepts the optional wide angle lenses offered by Epoque (DCL-20), Inon (UWL-100) and Sea&Sea (58070). These waterproof lenses secure to the outside of the lens port, and are not marketed by Ikelite.

Should you elect to use the optional Epoque, Inon or Sea&Sea lens, carefully thread the waterproof lens on the front of the lens port. The lens threads are very fine; DO NOT cross thread. It should screw on very easily. If it is difficult to turn, you are cross threading.

### LCD MONITOR / EXTERNAL MIRROR

The camera's LCD monitor can be viewed from the rear of the housing, using the external mirror featured on the side of the housing.

During transportation, please remember to close the mirror by pressing it against the side of the housing.

Open the LCD monitor on the camera, rotate 180°, and then press it back against the side of the camera. The external mirror is hinged so that it can be opened to reflect the image from the camera's LCD monitor for viewing from the rear of the housing.

The image is reversed in the LCD display. Looking in the mirror, Right is Left, Left is Right as you view your subject.

## BATTERY AND TAPE

- Install a fully charged Canon battery on the camera:  
Canon NB-2LH, BP-2L13
- Other brand batteries may not fit inside the housing.
- Make sure you have loaded an appropriate digital cassette tape in the camera.

## FINAL PREPARATION

The program selector on the camera **MUST** be in the [P] position for the focus lock button to function.

The camera's auto focus feature is utilized underwater. For best results, move in close to your subject and use the wide angle range to shoot thru as little water as possible. The full zoom range is accessible underwater. Chart shows recommended initial settings underwater.

CAMERA	SETTING
Power On/Off	- Camera (On)
Zoom Lever	- Wide Angle Setting
Focus	- Auto Mode
Exposure	- Auto Mode
Lens Cover Switch	- Open

## WHITE BALANCE

Initially set the white balance to Auto. Use the touch screen controls on the housing to change white balance.

**Color Filter:** When using the color filter (during the day), set camera white balance to Indoor for 0-15 foot depth. For 15-80 foot depth, set white balance to Outdoor.

**Video-Lite:** When using optional Video Lite at NIGHT, set the camera white balance to the Indoor position. During the DAY, use the Outdoor setting for subjects beyond 4-5 feet and the Indoor setting for closer subjects.

# INSTALLATION

## CAMERA TRAY

The camera mounts to the tray, which extends from the back plate of the housing. **DO NOT** remove the tray from the back plate.

Position the camera against the two stabilizing pins on the tray and secure camera with the tripod mounting bolt. The camera should fit easily on the tray and should be parallel with the sides of the tray.

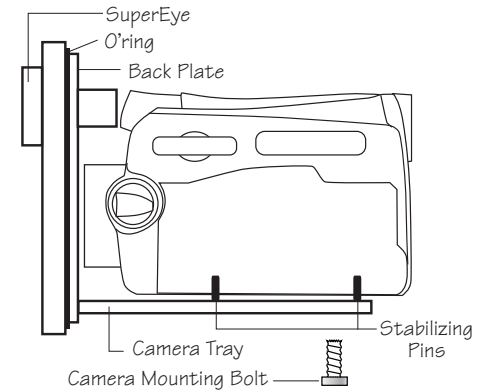

## INSERTING THE CAMERA

Check that the o'ring is clean and properly positioned on the lip of the clear housing back plate.

Once the camera is mounted to the tray as shown above, pull the housing controls out to provide clearance for installing the camera. Slowly slide the camera tray (with camera mounted) back into the housing. As the camera slides into the housing, make sure the camera lens fits into the port recess in the front of the housing.

**DO NOT** force this installation; the camera and tray should slide easily into place so the housings back plate o'ring is resting against the main housing body. In this position the lid snaps can be positioned over the lid hooks on the housing back plate and snapped into position to seal the housing.

## HOUSING CONTROLS

Slide the housing controls back in place making sure they properly align with the camera functions.

Operate each control to see how it works with the camera. Some controls such as start/stop will be used frequently. Other controls may seldom be utilized. Refer to your camera owner's manual for the proper function of each camera control. Look thru the back to be sure that you can see into the viewfinder.

*When using the housing controls, especially the start/stop, do NOT use excessive force because you could damage the camera.*

## CAUTION

*Remove the lens cap and cord from the camera. Otherwise, the cord may interfere with the housing seal. If the housing controls are not properly positioned, they could interfere with the housing seal.*

## IKELITE UNDERWATER SYSTEMS

50 West 33rd Street • PO Box 88100 • Indianapolis, IN 46208 USA

317.923.4523

Email: [ikelite@ikelite.com](mailto:ikelite@ikelite.com) • [www.ikelite.com](http://www.ikelite.com)

6047-01-0708