

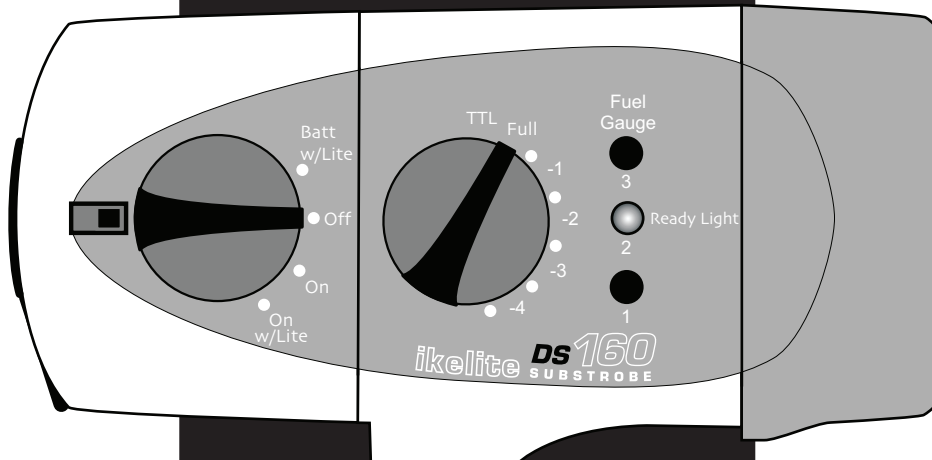

Digital Substrobe



DS160 #4060

TABLE OF CONTENTS

IKELITE DS160 SUBSTROBE	3,5	Triggered via Slave Sensor	18
Specifications	3	SMART CHARGER #4066.1	19
Introduction	4	Smart Charger #4066.1	19
Starting Out	4	Smart Charger Components	19
Strobe Compatibility	4	Smart Charger Indicator Light	19
Strobe Power	4	RECOMMENDATIONS	20
DS160 Substrobe	5	Visual Inspections	20
Overview of DS160 Features	5	Insurance	20
Becoming Familiar	5	Tips	20
OPENING AND CLOSING	6,7	Lubricant	20
Opening the Strobe	6	MAINTENANCE	21
Recharge the Battery Pack	6	Cleaning and Storage	21
Closing the Strobe	6	TROUBLESHOOTING	22
Opening and Closing (Illustrations)	7	Strobe Will Not Fire	22
NiMH BATTERY PACK	8	FLOODING	23
Charging the NiMH Pack	8	WARRANTY SERVICE	24
FLASH DIFFUSER	9	Ikelite Limited Warranty	24
Using the Diffuser	9	Returning Products for Service	24
Diffuser Installation and Removal	9		
ARM SYSTEMS/STROBE MOUNTS	10		
Ikelite Arm Systems	10		
Ikelite Mounts	10		
STROBE CONNECTION	11,12		
Strobe Connection (Illustration)	12		
USING AS A HARD-WIRED STROBE	13		
USING AS A HARD-WIRED STROBE WITHOUT TTL	13		
USING AS A SLAVE STROBE	14		
AIMING THE STROBE	15		
SWITCHES / FUEL GAUGE	16,17		
On/Off Switch	16		
Fuel GAUGE	17		
Confidence Signal	17		
Firing Mode Switch	17		
STROBE READY LIGHT	18		
Strobe Ready Light and TTL Housing	18		
Camera Ready Light	18		
Triggered via Sync Cord	18		

Note: Please read all instructions before using this product.

IKELITE DS160 SUBSTROBE

DS160 SPECIFICATIONS

CE - Compliant with applicable EU directives

Complies with FCC part 15, subpart B, Section 15.109 for Class "B" Products

Specifications

Battery Pack	NiMH module
Weight	1.3 kg (2.75 lb)
Size	9.6 cm dia x 17.9 cm..... 3.75" dia x 7"
Depth Rating	90m - 300 feet

Strobe

Energy Rating	160 watt-sec
Recycle Time	1.5 sec
Angle of Coverage.....	90 degrees..... 100 degrees with diffuser
Guide # (ISO 100) feet.....	76 surface - 38 underwater
Guide # meters	24 surface - 12 underwater
Color Temperature	4800 degrees Kelvin
Full Power Flashes	225 flashes per full charge
Firing Modes	TTL, Full, 9 fractional powers

Modeling Light

Modeling Light	5-watt LED
----------------------	------------

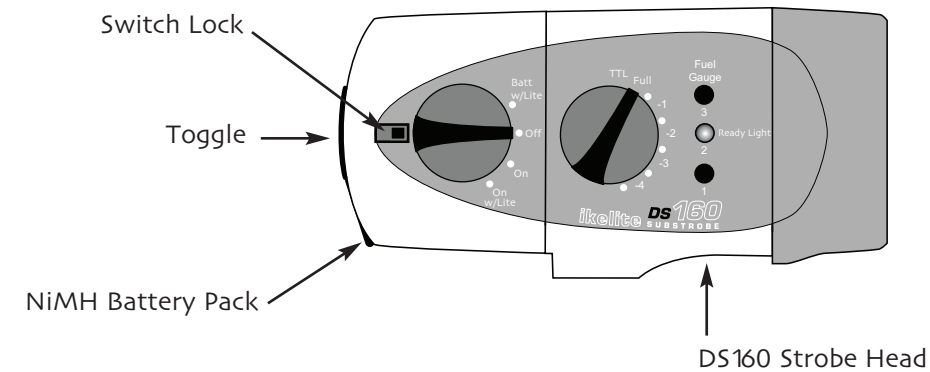

IKELITE DS160 SUBSTROBE (cont.)

INTRODUCTION

Thank you for purchasing an Ikelite Substrobe. Ikelite brings over 45 years of underwater photographic and lighting experience to the strobe market. Ikelite Substrobes are designed and built in the USA by Ikelite to suit both the professional and the amateur photographer.

The purpose of a strobe is to illuminate the subject and assist the camera in taking vivid pictures. The Ikelite DS160 Substrobe is equally suited for general and wide-angle photography, covering up to a full 100° angle with a diffuser.

This strobe is everything you need for stunning photos.

STARTING OUT

Before using the Ikelite DS160 Substrobe, please read this owner's manual thoroughly and retain it for future reference. Ikelite recommends becoming familiar with the features and functions of the Ikelite DS160 Substrobe above water before trying the camera and strobe in the water. And, if you have not yet done so, it is suggested that you read your camera's owner's manual as well.

STROBE COMPATIBILITY

The DS160 Substrobe is compatible with all Ikelite TTL systems and current digital cameras, as well as all older TTL film cameras including the Nikonos system. A variety of sync cords, sensors, and TTL adapters are available to connect to almost any camera system currently on the market.

STROBE POWER

The DS160 recycles in a quick 1.5 sec from full discharge. When fired at a fractional power — whether in TTL or manual mode — the strobe recycles virtually instantaneously. Number of flashes per full charge will increase dramatically in most cases when using in TTL mode with a compatible camera system. The powerful DS160 is adjustable in 10 half-stop increments for precise control over your exposure when used in manual mode.

IKELITE DS160 SUBSTROBE (cont.)

DS160 SUBSTROBE

The Ikelite DS160 strobe combines high intensity output and wide coverage angle in a compact, versatile design. This strobe features 160 watt-sec. intensity and covers a full 100° using the diffuser. Special soft-lite reflector provides rich reds, oranges, and warmer flesh tones.

The Ikelite DS160 strobe is pre-flash compatible and operates with both traditional film cameras and digital still cameras. Multiple firing modes are featured, including TTL/Auto exposure.

The DS160 electronics are safely sealed separately from the battery pack. The industrial grade NiMH batteries recycle in an incredible 1.5 seconds and the NiMH pack is easily interchangeable with a spare unit. When in the "Batt w/Lite" position, the fuel gauge references the remaining battery capacity. Aim the DS160 and illuminate your subject's colors with the built-in modeling light / night diving light.

OVERVIEW OF DS160 FEATURES

- Separate power and firing mode switches.
- Interchangeable battery pack features industrial grade NiMH batteries.
- LED fuel gauge approximates the remaining battery capacity.
- Visual ready light indicates when strobe has recycled.
- Female Ikelite bulkhead connector accepts different camera sync cords and the EV-Controller #4100.6.
- Exposure guide label references recommended exposure settings.
- Separate diffuser provides softer lighting and wider coverage angle.

BECOMING FAMILIAR

Before using the Ikelite Substrobe, please read this owners manual thoroughly and retain for future reference. We recommend that you become familiar with the features and functions of the Ikelite Substrobe before trying the camera and strobe in the water. And if you have not done so, we suggest reading your camera owner's manual.

OPENING AND CLOSING

Always turn the Substrobe OFF before opening.

OPENING THE STROBE

Turn the strobe OFF, and place the strobe face down on a flat surface.

Slide the locking lever out by either grasping the sides of the lever and pulling it out OR use your thumb to apply slight pressure to the top of the lever and slide it out.

Flip the lever up and then rotate the lever counter-clockwise 90°. The internal spring automatically pushes open the strobe. Lift the rear section off of the strobe front (See illustrations on page 7). The rear section is the NiMH battery pack for the strobe.

The NiMH pack does NOT remain waterproof when removed from the strobe. Therefore, we suggest keeping the open portion of the NiMH pack pointed down while removing to eliminate the possibility of water droplets falling inside. The NiMH batteries remain permanently secured inside the pack.

The front section of the DS161, which houses the main electronics, is safely sealed separately from the NiMH pack. The front section will remain waterproof when the NiMH pack is removed. However, avoid salt-water contact with the battery pins. Damage/corrosion can cause a short circuit. **DO NOT** disassemble the strobe or the NiMH pack. We suggest storage of your strobe with the locking lever OPEN to allow any hydrogen/air mixture to escape.

O-RING

The o-ring is located on the inside rim of the NiMH pack. Keep the o-ring and the sealing surfaces clean. **DO NOT** stretch the o-ring when cleaning. It is not necessary to lubricate the o-ring. Never use spray lubricant because it may crack the plastic.

RECHARGE THE BATTERY PACK

See "NiMH BATTERY PACK" section for recharging information (page 8).

CLOSING THE STROBE

Make sure the power switch has been rotated to the off position.

Place the front of the strobe face down on a flat surface. Check that the o-ring and sealing surfaces are clean; make sure the o-ring is positioned properly inside the rim of the NiMH pack. Place the locking lever in the open position (slide the lever out, flip the lever up, and rotate the lever counterclockwise 90 degrees until it stops).

Align the front and rear sections of the strobe. Lower the NiMH pack onto the front section of the strobe. Proper alignment of the two sections is extremely important to avoid possible damage to the internal components.

To seal the strobe, simply press down slightly on the rear of the NiMH pack and rotate the lever clockwise 90 degrees until it stops. Flip the lever down and then slide the lever into the locked position to properly seal the strobe.

OPENING AND CLOSING (CONT.)

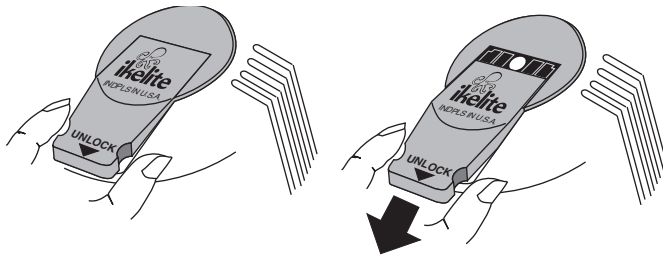

Pull Out

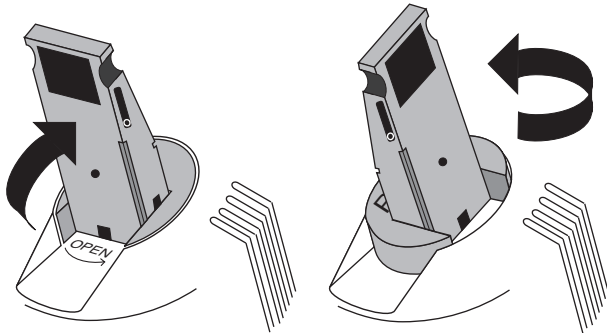

Flip Up

Rotate

NiMH BATTERY PACK #4066.5

The #4061 DS160 comes standard with rechargeable NiMH battery pack and flash diffuser (page 9). The NiMH battery pack requires #4066.1 Smart Charger (page 19), not included except with certain strobe packages.

Rechargeable NiMH battery pack #4066.5 is compatible only with Ikelite's DS160 and DS161 strobe. It is the only battery pack usable in the DS160 AND DS161. The rear section of the strobe is the NiMH battery pack for the strobe. Additional NiMH packs (rear sections) #4066.5 are available through an Ikelite dealer. Battery pack is also compatible with older DS125 strobes.

A fully charged NiMH pack provides at least **225 full power flashes**. It consists of six sub-C-cell industrial grade NiMH batteries (1.8Ah rating).

The NiMH pack does NOT remain waterproof when removed from the strobe. Therefore, we suggest keeping the open portion of the NiMH pack pointed down while removing to eliminate the possibility of water droplets falling inside. The NiMH batteries remain permanently secured inside the pack. **DO NOT disassemble the NiMH pack or charger.**

The DS160 accepts the same #4066.5 NiMH module used on our older DS125 Substrobes. If you intend to use an older battery pack on your new Substrobe, please reference the notice dated 6/22/09 on the following webpage:
http://www.ikelite.com/web_pages/important.html

CHARGING THE NiMH PACK

Recharge the NiMH pack after each use. **DO NOT** fully discharge NiMHs as this shortens the battery life. Recharge the NiMHs if the modeling light dims or if the recycle time exceeds 8-10 seconds; batteries are nearly depleted. Store the NiMH pack fully charged and recharge the pack for a few hours each month. In our application, the NiMHs should NOT develop a memory. Fully discharging the NiMHs or allowing the NiMHs to completely lose a charge does far more damage than any risk of NiMH memory.

NiMH Module #4066.5

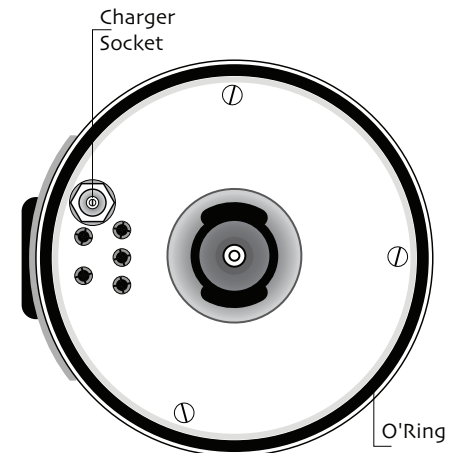

FLASH DIFFUSER #0591.3

USING THE DIFFUSER

The white diffuser can be secured to the front of the DS160 strobe when softer lighting or a coverage angle of 100° is desired.

The diffuser reduces the DS160's light intensity by one full f-stop.

DIFFUSER INSTALLATION AND REMOVAL

1. Position the Diffuser Cut-outs over the DS160 strobe's Diffuser Retention Tabs.
2. Press down lightly until the diffuser is flush against the strobe face.
3. Rotate the Diffuser Installation Posts either direction until the Posts stop against the strobe's Diffuser Retention Tabs.
4. Reverse process to remove the Diffuser.

- A lanyard or string can be attached to the diffuser by threading it through the two Lanyard Holes near its edge. Attach the other end to the strobe to prevent accidental loss.

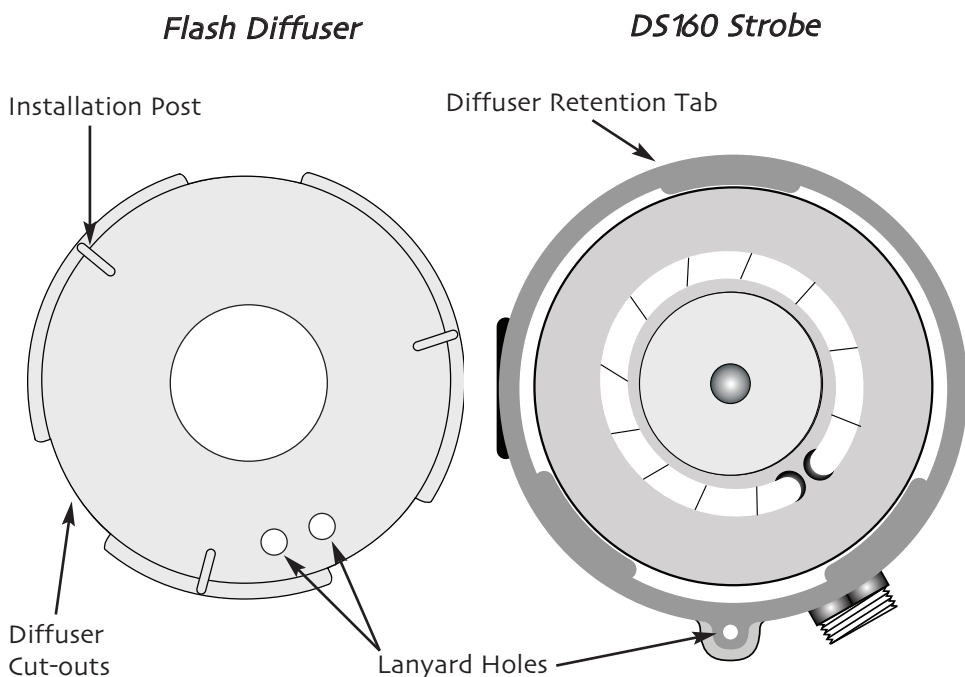

ARM SYSTEMS / STROBE MOUNTS

IKELITE ARM SYSTEMS

Ikelite offers several arm choices compatible with the DS160. The arm and strobe mount are NOT supplied with the strobe unless purchased as part of a complete package. For additional information go to www.ikelite.com

Caution: Ikelite arm systems are designed for underwater use. Be careful when transporting the system above water since some camera trays and arm adjustments may be unable to support the weight of the strobe(s) above water.

IKELITE MOUNTS

An optional paddle-type or ball-type mount can be mounted to the underneath side of the strobe. The mount slides into the strobe base and is secured with a screw (supplied with optional mount). Make sure to slide the mount into the strobe base until it stops. Be careful to not cross-thread the screw when tightening the mount. The DS160 can be rotated slightly to gain better access to the strobe base with a screwdriver. Although not necessary, you can apply a small amount of Ikelite lube around the screw threads before attaching the strobe mount. Use Ikelite lube only which is supplied with the DS161 strobe. This will reduce the possibility of seizing and allow removal of the screw should the mount need to be removed. Removing the mount for long storage periods will also reduce the possibility of seizing.

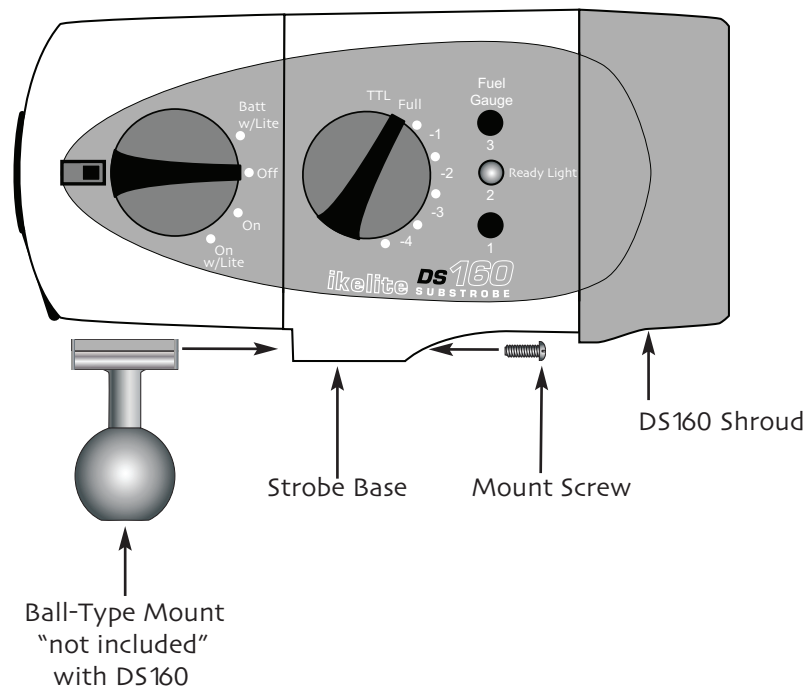

STROBE CONNECTION

The female Ikelite bulkhead connector permits different Ikelite sync cords or the Ikelite EV manual controller sensor to be connected to the strobe. The sync cord or sensor relays a signal from the camera to the substrobe that tells the DS160 when to flash.

The removable waterproof bulkhead cap seals the bulkhead connector when neither a cord nor a sensor is connected to the DS160. The strobe's bulkhead connection must be sealed to remain waterproof (page 12).

Caution:

- **Do not** leave the sync cord or sensor connected to the camera or strobe for prolonged periods as electrolysis could occur and make removal of the equipment impossible.
- **Do not** disconnect the sync cord or sensor from the housing or strobe when underwater or when wet. These items are not waterproof when disconnected.
- Make sure there is no debris on the sync cord o-ring and the sync cord connector is aligned properly when attaching to the strobe bulkhead (page 12).

CONNECTION TO STROBE

To connect either a sync cord or sensor to the DS160 Substrobe, follow these instructions:

1. Turn the substrobe to OFF and make sure all components are dry. Clean and lightly lubricate the stem o-ring and the bulkhead connector threads. Check the o-ring for nicks or cuts.
2. Note the positioning of the receptacles and pins on the end of the cord. Properly align the end of the cord and insert it into the strobe bulkhead connector. When using the #4103.51 cord, which connects an Ikelite housing to an Ikelite Substrobe, both cord ends are identical; either end can be connected to the strobe.
3. The connector threads are very fine; do not cross thread. If it is difficult to turn the knurled retaining ring on the cord or sensor, you are likely cross-threading. This can make removal of the strobe or sensor impossible. Hand-tighten the knurled retaining ring on the cord or sensor. Push the end of the cord further into the bulkhead connector and continue to tighten the knurled retaining ring. **Do not** use pliers or a tool when tightening. It could damage the cord or strobe.

STROBE CONNECTION (CONT.)

DS160Strobe

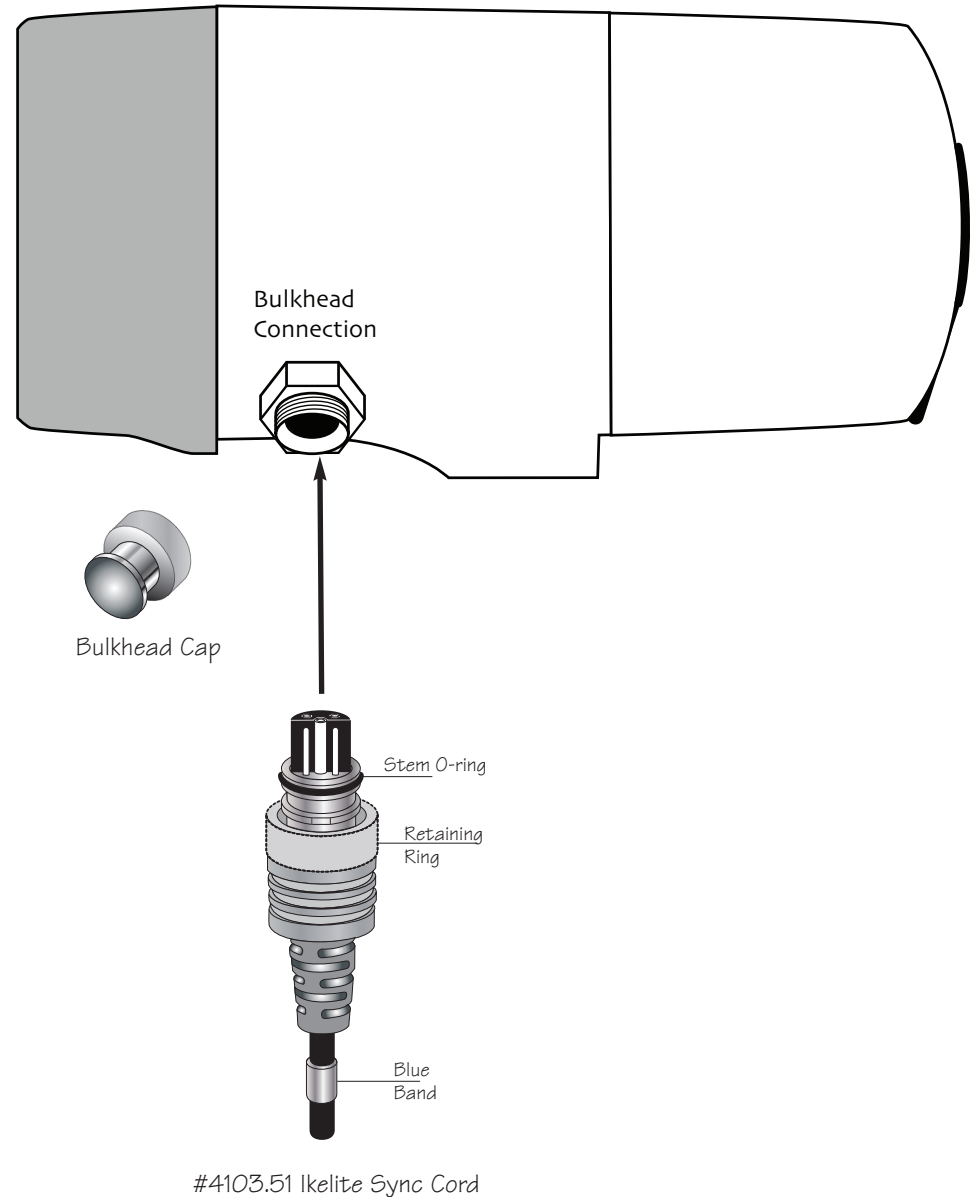

USING AS A TTL HARD-WIRED STROBE

For use with the following types of systems:

- Ikelite housings for digital cameras with TTL conversion circuitry
- Ikelite housings for film cameras
- Nikonos V, RS cameras
- Non-Ikelite housings for digital cameras and compatible TTL adapter

Connect the strobe using an appropriate Ikelite TTL sync cord. Digital dSLR cameras require the use of a Digital TTL sync cord. These cords are designated by a blue band at one end. The DS160 may be used in TTL(Auto) or manual exposure modes.

TTL (thru-the-lens) exposure automatically compensates for aperture, distance and filters. Because there's such a wide range of apertures and subject distances, photographers wanting to easily balance lighting and control close-up photography should select the TTL(Auto) exposure mode. When the strobe fires, the camera reads the light and signals the strobe to turn off when the exposure is correct.

Strobe output can be adjusted in TTL(Auto) mode using either exposure compensation built into the camera or an exposure compensation module in the back of the housing (if applicable).

If an exposure compensation module is featured in the back of the housing, strobe output may be controlled manually while the strobe itself is left in TTL(Auto) mode. In order to use the manual exposure modes on the strobe itself, the housing module must be set in a manual position.

When using a non-Ikelite TTL adapter or third party conversion circuitry, please refer to the product's instructions for help in using the DS160 with this setup.

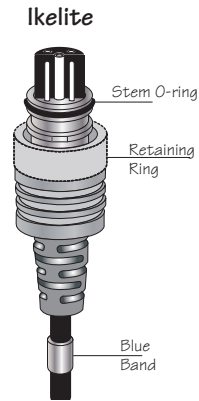

USING AS A HARD-WIRED STROBE WITHOUT TTL

For use with the following types of systems:

- Ikelite housings for digital cameras with external strobe connector but without TTL conversion circuitry
- Non-Ikelite housings for digital cameras with Nikonos-style strobe connector

Connect the strobe using an appropriate Ikelite sync cord. The DS160 must be used in manual exposure modes. Strobe output is not automatically adjusted for proper exposure when set to TTL(Auto) mode.

USING AS A SLAVE STROBE

For use with the following types of systems:

- Ikelite or non-Ikelite housings without external strobe connector

The EV Manual Controller #4100.6 is required to use the DS160 as a slave strobe. The EV Controller watches the camera's built-in flash and triggers the strobe at the appropriate time.

Set the DS160 mode switch to "TTL" to utilize the power settings on the EV Manual Controller. If the DS160 is set to a manual exposure mode, the power settings of the EV Manual Controller are ignored.

The camera must be set to a "forced flash" mode, usually designated by a lightning bolt, in order for the DS160 to fire consistently in every photo. Both the camera's built-in flash and the DS160 must recycle completely before taking another flash photo.

Most digital cameras fire one or more short preflashes to help the camera determine focus, exposure and color balance. After the preflash(es), the camera's built-in flash fires to illuminate the subject while the photo is taken. Both the EV Manual Controller and the Substrobe DS160 are preflash compatible. The internal switches on the EV Controller must be set properly for the DS160 to fire at the correct time. Refer to the EV Manual Controller instruction manual for more information.

If the DS160 fires at the incorrect time resulting in a dark photo, the preflash setting is most likely incorrect. Check both the preflash switch on the EV Controller and the camera's exposure mode. Some digital cameras such as the Canon G-series fire a preflash in Auto, Program, shutter priority and aperture priority modes, but not manual exposure modes.

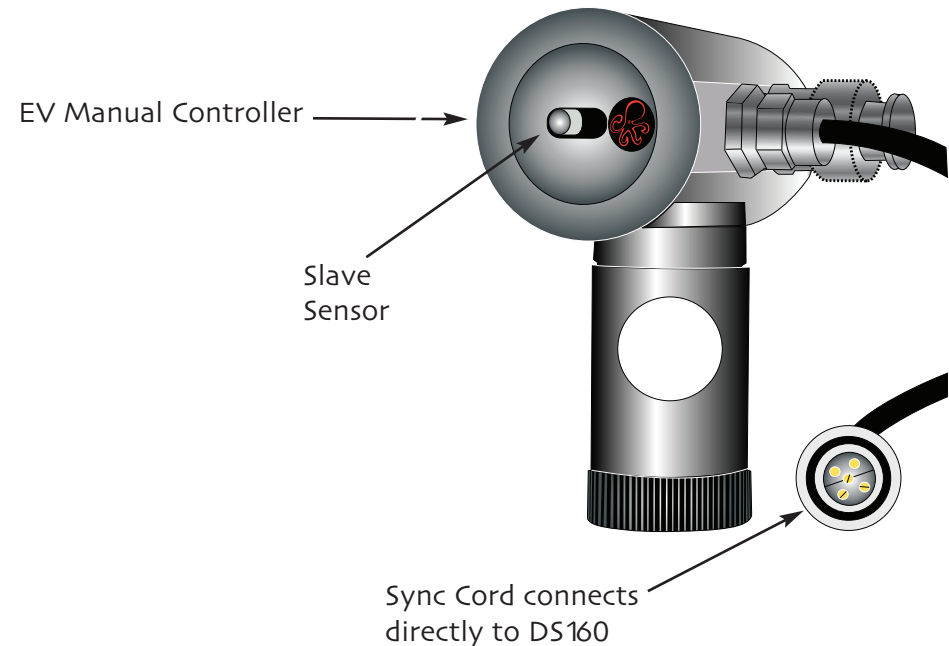

AIMING THE STROBE

AIMING THE STROBE

Use the modeling light to aim the strobe. Look thru the camera's viewfinder, and aim the strobe so that the modeling light shines in the center of your picture area. If your subject distance greatly changes, you should recheck the positioning of the strobe.

When using auto-focus cameras, the modeling light may be required in low light levels to illuminate your subject to allow the camera to auto focus.

DS160 Strobe

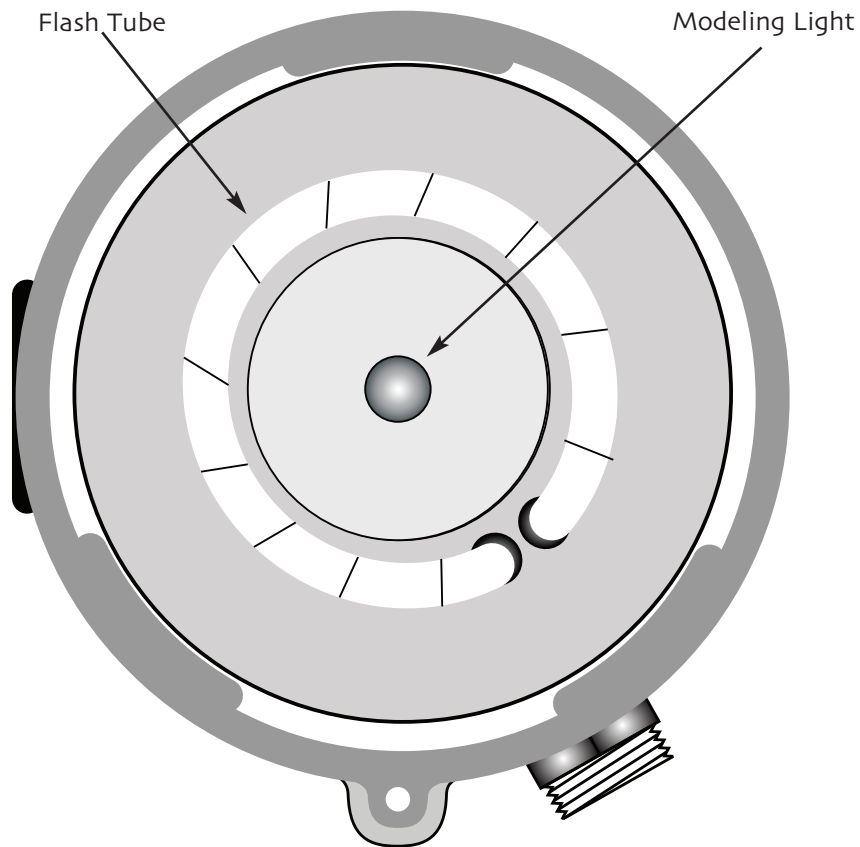

SWITCHES / FUEL GAUGE

The DS160 features separate switches for power on/off and firing modes. The arrow on the switch points to the selected position.

ON/OFF SWITCH

OFF: The horizontal switch position is OFF. The adjacent tab locks the switch in the OFF position. To unlock, slide the tab away from the switch. Always turn the Substrobe OFF before opening the strobe.

ON: There are two ON positions. Rotating the switch clockwise to the first ON position turns on the power to the Substrobe. Further rotation of the switch clockwise to the second ON position turns on both the power to the Substrobe and the movie light.

TEST: Occasionally check the battery capacity by rotating the switch counter-clockwise to the "Batt w/Lite" battery position and referencing the fuel gauge on the side of the strobe. The "Batt w/Lite" battery position also turns ON the movie light.

DS160 Strobe

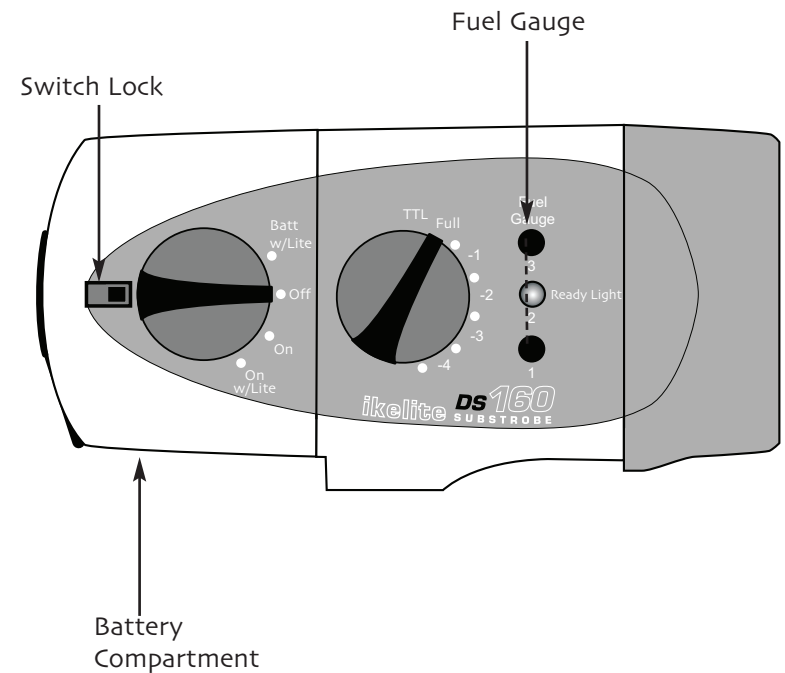

SWITCHES/FUEL GAUGE (CONT.)

FUEL GAUGE

When the switch is rotated to the "Batt w/Lite" position, the fuel gauge on the side of the strobe will display 0, 1, 2, or 3 red LED lights indicating the remaining charge in the battery pack (see below). A fully charged NiMH pack will provide at least 225 full power flashes and all 3 LED's should light. When no LED's are illuminated, then the battery capacity is low and you may have less than 36 full power flashes remaining. For general guidelines, refer to the following list:

- 3 LED's - above 75%
- 2 LED's - above 50%
- 1 LED - above 25%
- No LED - less than 25%

CONFIDENCE SIGNAL

The DS160 strobe features a confidence signal indicator light that will glow if the strobe properly exposes the picture. The #3 LED on the fuel gauge will glow GREEN for three seconds if the DS160 strobe quenches, indicating that the strobe has provided proper exposure. This green confidence light illuminates only in the TTL exposure mode when used with compatible TTL systems.

FIRING MODE SWITCH

Multiple firing modes are featured: TTL/Auto and 9 fractional power settings from the Full power setting: Full, -1/2, -1, -1 1/2, -2, -2 1/2, -3, -3 1/2, -4, -4 1/2.

TTL(Auto) - Thru-The-Lens/Auto Exposure: The camera automatically signals the strobe to turn off when the exposure is correct. The camera must feature compatible TTL(Auto) exposure to utilize this mode on the DS160 when connected directly to the camera. (See "Using as a Hard-Wired TTL Strobe" section). The TTL(Auto) firing mode MUST be selected when connecting the optional EV-Controller #4100.6.

Full - Full Power Manual Exposure: The strobe fires at full power each time. You must select the correct exposure manually. Set the camera aperture based on the subject distance (see "Exposure Guide" section).

Fractional Power Settings: Select the appropriate power setting to manually balance the strobe output for available light. Select a fractional power setting when the strobe-to-subject distance is fixed and the manual full power setting would over-expose with the camera's selected aperture. The difference between **each power setting** is one-half an f-stop; moving from Full power to -1/2 decreases the light output by one-half an f-stop. Changing the power setting does not alter the coverage angle.

STROBE READY LIGHT

STROBE READY LIGHT AND TTL HOUSING

The Ikelite DS160 Substrobe features a ready light that glows red when the DS160 has recycled and is ready to fire its flash again.

The middle #2 LED on the fuel gauge functions as the visual ready light. The DS160 also features a confidence light that will glow if the strobe properly exposes the picture. The #3 LED on the fuel gauge will glow GREEN for three seconds if the DS160 strobe quenches, indicating that the strobe has provided proper exposure. This green confidence light illuminates only in the TTL exposure mode. If no green light appears, check the image for possible under-exposure. When the strobe has recycled again, the ready light will again glow red indicating that the strobe is fully powered and ready to fire. If the strobe ready light does not glow red, the batteries may be expended.

Your camera's ready light "lightning bolt" in the camera viewfinder may blink while the DS160 is recycling and then glow solid when the DS160 is fully charged. Nikon dSLRs and older Canon dSLR models such as the 20D and Rebel XT will always display a solid glow "lightning bolt" regardless of the strobe cycle.

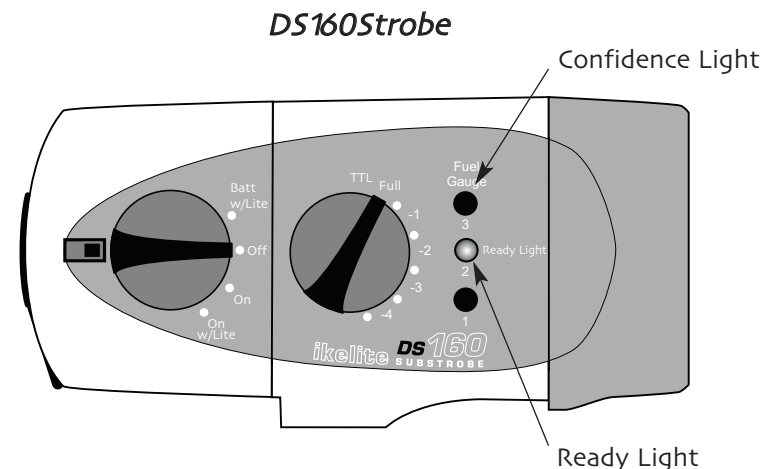

CAMERA READY LIGHT

Triggered via Sync Cord

When using a TTL/Auto exposure camera (film or digital) in an Ikelite TTL compatible housing connected to the DS160 strobe by sync cord, the flash ready light in the camera viewfinder and the DS160 ready light will both glow when the Substrobe has recycled and is ready to fire.

If the Ikelite housing does not feature TTL compatible circuitry, then the ready light in the camera viewfinder would not be triggered when the strobe has recycled.

Triggered via Slave Sensor

When using the DS160 strobe with the optional EV-Controller (without optional sync cord), the strobe is not electronically connected to the camera. Therefore, the ready light in the viewfinder of the camera only indicates when the on-camera flash has recycled. Reference both the camera and DS160 ready lights to make sure both flashes have fully recycled before taking the next picture.

SMART CHARGER #4066.1

SMART CHARGER #4066.1

The Smart Charger #4066.1 is sold separately or included with certain strobe packages. The charger is a variable input voltage charger that automatically adjusts for the voltage of the power source, ranging from 100V to 240V. The Smart Charger adapts to current fluctuations in travel destinations with poorly regulated power. It provides more complete recharging, prolongs battery life, and offers trickle maintenance charge.

Charging Time

The Smart Charger will fully recharge the DS160 battery pack in 1.5 hrs.

Smart Charger Components

The Smart Charger #4066.1 offers use worldwide by accepting interchangeable adapter plugs for different electric wall outlets. It is packaged with four interchangeable charger plugs for USA, European, United Kingdom, and Australian electric outlets. Choose the appropriate charger plug for your location and slide the chosen plug on the back of the charger; it snaps into position. To interchange the charger plugs, press UP on the charger plug to unsnap it from the back of the charger and slide another plug into position.

Smart Charger Indicator Light

The charge indicator light on the Smart Charger shows the present recharge mode. It illuminates once connected to both the electric outlet and the Ikelite battery module. DS160 full recharge time with the Smart Charger is 1.5 hours. Afterwards, the Smart Charger will automatically switch to provide a trickle maintenance charge. Only the Smart Charger is capable of providing a trickle maintenance charge permitting the NiMH pack to be continuously charged for extended periods.

CONTINUOUS illuminated light

Indicates that the NiMH module is being quick-charged.

SLOW BLINKING illuminated light

Indicates that the NiMH module is fully recharged and the charger is now providing a trickle maintenance charge, which permits the NiMH module to be continuously charged for extended time periods.

RAPID BLINKING illuminated light

Indicates that the NiMH module was virtually drained (discharged) and the module is being slow-charged to bring up the NiMHs. Once the NiMHs reach an acceptable level, then the charger will automatically switch to the quick-charge mode.

Only use 5-6 cell Ikelite NiMH Charger

RECOMMENDATIONS

VISUAL INSPECTIONS

Visual inspections are important. Take the time to examine the entire assembled setup (strobe, camera housing, arms, etc.) above water. An improper seal or loose connection can cause a lot of damage. Always check for leaks once you place the equipment in the water.

INSURANCE

It is recommended that you add an **all-risk floater** to your homeowner's and/or renter's insurance policy to cover your equipment against loss or damage. While the Ikelite DS160 Substrobe has a limited warranty against manufacturing defects, it does not cover customer neglect.

TIPS

- Photograph through as little water as possible; move in close. Maximum recommended shooting distance underwater is 1.8m (6').
- Use the diffuser for softer lighting or a coverage angle of approximately 100°.
- If possible, measure the light with a meter and set the camera aperture accordingly. A narrower aperture darkens the background; a wider aperture lightens it.
- Add a second Substrobe DS160 for more natural looking photos and wider angle of coverage when shooting both still and video images. Add a second DS Substrobe using either the EV Manual Controller #4100.6 or an appropriate dual sync cord.
- Purchasing a spare #4066.5 NiMH Battery Pack is recommended if you dive often. Weak batteries are the cause of many strobe and camera problems.
- **Do not** fire the strobe more than 15 times in rapid succession. If this does happen, allow the DS160 to cool off for at least 10 minutes before resuming photography.

LUBRICANT

- Use **only** Ikelite brand silicone lubricant with Ikelite brand o-rings; other brand lubricants can cause the Ikelite o-rings to swell in size.
- **Do not** use spray lubricant; it can crack the plastic parts of the strobe.
- Ikelite brand silicone lubricant is provided for the sync cord stem o-ring and the bulkhead connector threads. Use only enough lubricant to lightly cover the area being applied; wipe off any excess with a clean cloth.
- Lubricant only reduces friction; it is not a sealant.

MAINTENANCE

Your Ikelite DS160 Substrobe should be given the same care and attention as your other photographic equipment. After using your strobe in water, please follow these instructions to ensure the DS160's longevity and good working order.

CLEANING AND STORAGE

1. Always rinse the exterior of the DS160 with fresh water after use, especially after exposure to salt water. While rinsing, turn the mode and power switches to free salt or debris that might have accumulated in the DS160's recesses during the dive. The strobe can be cleaned by soaking it in a mild soapy solution. Use liquid soap; RINSE and DRY the strobe before storage.
2. Check the NiMH battery o-ring sealing surface for any debris and gently wipe it away with a soft, lint free cloth.
3. Check the DS160's bulkhead connector threads for debris. Gently wipe away with a soft, lint free cloth or a cotton swab to clean the threads. Afterwards, lightly lubricate them.
4. The o-ring #0132.36 is located on the inside rim of the DS160 battery pack. Keep the o-ring and the sealing surfaces clean. **DO NOT** stretch the o-ring when cleaning. It is not necessary to lubricate the o-ring. Never use spray lubricant because it may crack the plastic.
5. Keep the strobe bulkhead connector threads clean and lightly lubricated. Also keep the sync cord o-ring and threads clean and lightly lubricated.
6. Recharge the NiMH pack after each use; **DO NOT** fully discharge the NiMHs because you will shorten the battery life. Store the NiMH pack fully charged, and recharge the pack for a few hours each month. **DO NOT** disassemble the battery pack.
7. The strobe is factory sealed; **DO NOT** disassemble.

In addition to these procedures, it is strongly recommended that this strobe be returned to Ikelite periodically for inspection and water pressure testing. Ideally your DS160 should undergo this process every two years or 100 dives, whichever comes first.

Caution:

- The DS160's bulkhead connector is not waterproof and must be capped when not connected to a cord or sensor. Using a DS160 underwater with the bulkhead connector uncapped or unconnected will cause the strobe to flood. DO NOT continue to use a flooded strobe; return to Ikelite for repair.
- The strobe is factory sealed; **do not** disassemble. Disassembly will void your Ikelite DS160's limited warranty.
- **Do not** continuously fire the strobe more than 15 times above water in rapid succession. If this does happen, allow the strobe to cool down for at least 10 minutes.

TROUBLESHOOTING

STROBE WILL NOT FIRE

1. Make sure the NiMH battery pack is fully charged.
2. Check the DS160's ready light. Turn the strobe's mode switch to OFF and then back to ON. Make sure that the switch has actually clicked into position.
3. Check the mode switches on the camera and strobe.
4. Check the cord connections at the camera and strobe.
5. When using a sync cord between the camera and strobe, disconnect the cord from the camera but leave the cord connected to the strobe. Then, use the two ends of a bent paper clip to connect different receptacles on the flash cord contacts, as detailed in the diagram below. This process, known also as "shorting," creates a temporary circuit that can test-fire the strobe.

Caution: When creating a circuit via paper clip, or "shorting," pay close attention to which two receptacles you connect. If you short across the wrong receptacles on a TTL sync cord, you may damage the DS160's electronics.

The specific receptacles to connect with the paper clip vary based on the type of cord you own. Please refer to the diagram of two types of flash cord contacts.

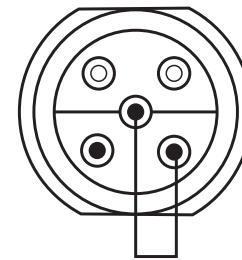

Ikelite

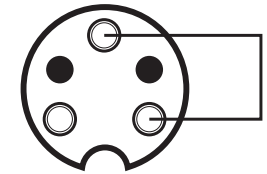

Nikonos

Ikelite TTL Cord: Point the raised half-circle at the end of the cord encompassing the receptacles towards you, per the above diagram. Place one end of the paper clip on the center receptacle and one end on the lower right-hand receptacle. The DS160 should flash.

Nikonos TTL Cord: Point the indexing groove at the end of the cord towards you, per the above diagram. Place one end of the paper clip on the top-most, center receptacle and one end on the lower, right-hand receptacle. The DS160 should flash.

If the DS160 flashes, the source of the problem lies somewhere in the camera. If the DS160 does not flash, please send both the strobe and cord used in the test to an authorized Ikelite dealer, or to Ikelite; see "Returning Products for Service" on page 24.

Do not attempt to repair the strobe or cord yourself. This may cause further damage and void your Ikelite limited warranty.

FLOODING

The DS160 electronics are safely sealed separately from the battery pack. Should the battery pack flood, flush with fresh water and dry thoroughly. Determine the cause of flooding. REPLACE THE COMPLETE BATTERY PACK #4066.5. Never re-use batteries that have been wet. The water could create an internal short circuit at some later date causing a potential explosion. DO NOT disassemble the strobe, NiMH pack.

Send the strobe head in for service if there is any discoloration of the battery pins.

WARRANTY SERVICE

IKELITE LIMITED WARRANTY

Ikelite Substrobes are warranted against any manufacturing defects for a period of two years from the original date of purchase. All other Ikelite products are warranted against any manufacturing defects for a period of one year from the original date of purchase. Defective products should be returned prepaid to Ikelite. Ikelite will, at its discretion, repair or replace such products, and will return them to the customer prepaid. All other claims, of any nature, including, but not limited to, bulb failure, are not covered. Except as mentioned above, no other warranty, expressed or implied, applies to this Ikelite product.

RETURNING PRODUCTS FOR SERVICE

Ikelite is most interested in performing any service to assure that all products perform as intended. For repair service, return the Ikelite product to the address below with your name, address, phone number, and a brief description of the problem. Evidence of purchase date must be provided to obtain warranty service. Thank you.



IKELITE UNDERWATER SYSTEMS

50 West 33rd Street
Indianapolis, IN 46208 USA

317-923-4523

www.ikelite.com

Email: ikelite@ikelite.com