



# Digital Substrobe



**DS51**  
**#4044.1**

## TABLE OF CONTENTS

<b>IKELITE DS51 DIGITAL SUBSTROBE</b> ....	3-4	Insurance .....	17
DS51 Specifications .....	3	Tips .....	17
Introduction.....	4	Lubricant .....	17
DS51 Substrobe Use.....	4	<b>MAINTENANCE</b> .....	18
Overview of DS51 Features .....	4	Cleaning and Storage .....	18
Starting Out.....	4	<b>TROUBLESHOOTING</b> .....	19
<b>MOUNTING THE STROBE</b> .....	5	Strobe Will Not Fire .....	19
Ikelite Arm/Mounting Systems .....	5	<b>WARRANTY SERVICE</b> .....	20
<b>LITE BRACKET #4073</b> .....	5	Ikelite Limited Warranty .....	20
<b>STROBE CONNECTION</b> .....	6	Returning Products for Service .....	20
Connection to Strobe .....	6-7		
TTL/Sync Cords .....	7		
<b>USING AS A TTL HARD-WIRED STROBE</b> .....	8		
<b>USING AS A HARD-WIRED STROBE WITHOUT TTL</b> .....	9		
<b>USING AS A SLAVE STROBE</b> .....	10		
<b>BATTERY COMPARTMENT</b> .....	11		
Opening the Compartment .....	11		
Battery Compartment O-ring .....	11		
Changing the Batteries.....	11		
Closing the Compartment .....	12		
Compartment Flooding .....	12		
<b>STROBE DIFFUSER</b> .....	13		
Using the Diffuser.....	13		
Diffuser Installation and Removal .....	13		
<b>STROBE READY LIGHT</b> .....	14		
Camera Ready Light .....	14		
<b>MODE SWITCH</b> .....	15		
Off Position .....	15		
TTL/auto Exposure Position.....	15		
Manual Exposure Position .....	15		
<b>MODE SWITCH ILLUSTRATIONS</b> .....	16		
<b>RECOMMENDATIONS</b> .....	17		
Visual Inspections .....	17		

Note: Please read all instructions before using this product.

# IKELITE DS51 SUBSTROBE

## DS51 SPECIFICATIONS

- Weight.....0.6kg (1.3 lbs.) with batteries
- Energy Rating:.....50 watt-sec.
- Coverage Angle:.....70° (80° with diffuser)
- Widest Angle Lens:.....28mm SLR
- Guide Number (ISO 100) feet:.....56 surface, 28 underwater
- Guide Number (ISO 100) meters:.....17 surface, 9 underwater
- Firing Modes:.....TTL/Auto, Full, 5 fractional powers
- Color Temperature:.....5700°K
- Power Source:.....4 AA-cell alkaline, NiCad, or NiMH
- Flashes:.....200 full power
- Recycle Time:.....3.5 seconds (full power)
- Depth Rating:.....90m (300 feet)
- CE - Compliant with applicable EU directives
- Complies with FCC part 15, subpart B, Section 15.109 for Class "B" Products

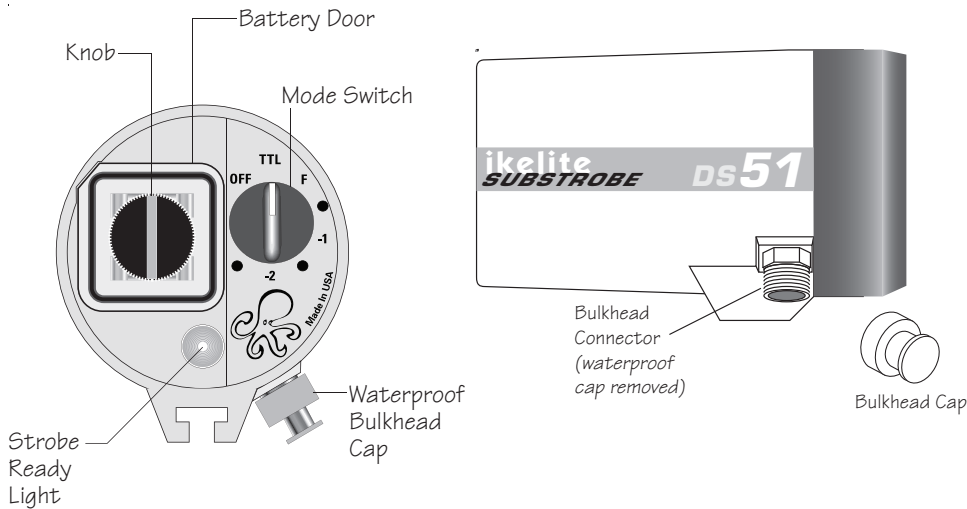

### Caution:

- The DS51's bulkhead connector is not waterproof and must be capped when not connected to a cord or sensor. Using a DS51 underwater with the bulkhead connector uncapped or unconnected will cause the strobe to flood. DO NOT continue to use a flooded strobe-return to Ikelite for repair.
- The strobe is factory sealed; **do not** disassemble. Disassembly will void your Ikelite DS51's limited warranty.
- **Do not** continuously fire the strobe more than 15 times above water in rapid succession. If this does happen, allow the strobe to cool down for at least 10 minutes.

# IKELITE DS51 SUBSTROBE

## INTRODUCTION

Thank you for purchasing an Ikelite Substrobe. Ikelite brings over 45 years of underwater photographic and lighting experience to the strobe market. Ikelite Substrobes are designed and built in the USA by Ikelite to suit both the professional and the amateur photographer.

## DS51 SUBSTROBE USE

The purpose of a strobe is to illuminate the subject and assist the camera in taking vivid pictures. The Ikelite DS51 strobe is equally suited for general and wide-angle photography, covering up to 80° with a diffuser. The compact size of the DS51 makes it ideal for macro photography while its 5700°K-color temperature helps bring out the true colors of the underwater world.

The Ikelite DS51 strobe is preflash compatible and operates with traditional film cameras, dSLR cameras, and digital still cameras. TTL/auto and manual exposure with 5 fractional power setting firing modes are featured. The DS51's electronics are safely sealed away from the battery compartment.

Aim the DS51 strobe and illuminate your subject's colors with the optional Mini-C Lite and Lite Bracket #4073 (page 5). The bracket secures beneath the strobe, allowing the Mini-C Lite to be used as both an aiming light and as a night diving light.

## OVERVIEW OF DS51 FEATURES

- Mode switch features TTL/auto and manual exposure settings.
- Battery compartment accommodates four AA batteries: alkaline, NiCad, or NiMH. Lithium Ion batteries are NOT recommended.
- Ready light indicates when strobe has recycled.
- Female Ikelite bulkhead connector accepts different camera sync cords and the EV Manual Controller #4100.6.
- Exposure guide label references recommended exposure settings.
- Diffuser provides softer lighting, wider coverage angle and reduces strobe output by one f-stop.

## STARTING OUT

Before using the Ikelite DS51 Substrobe, please read this owner's manual thoroughly and retain it for future reference. Ikelite recommends becoming familiar with the features and functions of the Ikelite DS51 Substrobe above water before trying the camera and strobe in the water. And, if you have not yet done so, it is suggested that you read your camera's owner's manual as well.

# MOUNTING THE STROBE

## IKELITE ARM/MOUNTING SYSTEMS

Ikelite offers several arm choices compatible with the DS51. Arms and mounts are NOT supplied with the strobe unless purchased as part of a complete package.

The DS51 will accept several Ikelite strobe arms and mounts on the underside of the strobe body. For further information, please visit our "Strobe Mounting Systems" webpage: [http://www.ikelite.com/web\\_pages/arms.html](http://www.ikelite.com/web_pages/arms.html).

**Caution:** Ikelite arm systems are designed for underwater use. Be careful when transporting the system above water since some camera trays, or arm adjustments may be unable to support the weight of the strobe(s) above water.

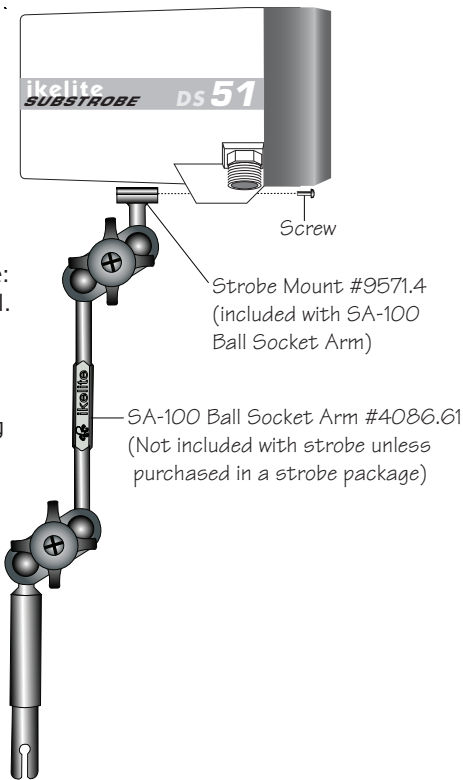

# Lite Bracket #4073

The optional Lite Bracket secures the Ikelite Mini-C Lite underneath the DS51 strobe for use as an aiming light and night diving light.

The Lite Bracket is placed between the strobe body and the strobe mount. Using a Phillips Head screwdriver, remove the strobe mount from the underside of the strobe and secure the Lite Bracket in its place. Then, using the extra screw provided with the Lite Bracket, secure the strobe mount under the bracket.

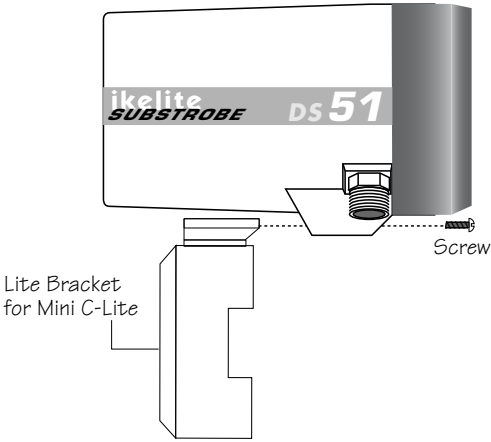

# STROBE CONNECTION

The female Ikelite bulkhead connector permits different Ikelite sync cords or the Ikelite EV manual controller sensor to be connected to the strobe. The sync cord or sensor relays a signal from the camera to the substrobe that tells the DS51 when to flash.

The removable waterproof bulkhead cap seals the bulkhead connector when neither a cord nor a sensor is connected to the DS51. The strobe's bulkhead connector must be sealed to remain waterproof (page 7).

## Caution:

- **Do not** leave the sync cord or sensor connected to the camera or strobe for prolonged periods as electrolysis could occur and make removal of the equipment impossible.
- **Do not** disconnect the sync cord or sensor from the camera or strobe when underwater or when wet. These items are not waterproof when disconnected.

## CONNECTION TO STROBE

To connect either a sync cord or sensor to the DS51 Substrobe, follow these instructions:

1. Turn the substrobe to OFF and make sure all components are dry. Clean and lightly lubricate the stem o-ring and the bulkhead connector threads. Check the o-ring for nicks or cuts.
2. Note the positioning of the receptacles and pins on the end of the cord. Properly align the end of the cord and insert it into the strobe bulkhead connector. When using the #4103.51 cord, which connects an Ikelite housing to an Ikelite Substrobe, both cord ends are identical; either end can be connected to the strobe.
3. The connector threads are very fine; do not cross thread. If it is difficult to turn the knurled retaining ring on the cord or sensor, you are cross-threading. This can make removal of the strobe or sensor impossible.

Hand-tighten the knurled retaining ring on the cord or sensor. Push the end of the cord further into the bulkhead connector and continue to tighten the knurled retaining ring. **Do not** use a tool when tightening. It could damage the cord or strobe.

## STROBE CONNECTION cont.

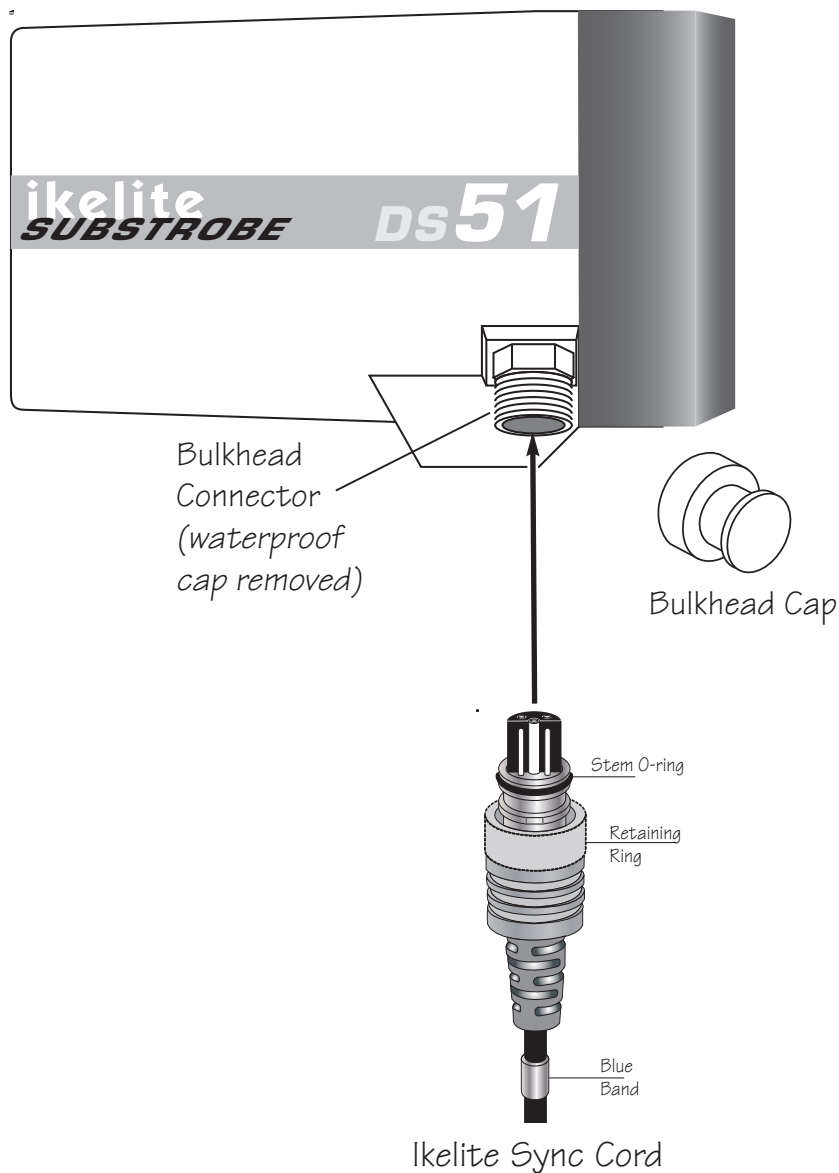

### TTL SYNC CORDS

Ikelite offers interchangeable sync cords so that the DS51 strobe can be connected to different camera systems. A TTL sync cord (illustrated above) is required to send the TTL/auto exposure signal from the camera to the strobe.

## USING AS A TTL HARD-WIRED STROBE

For use with the following types of systems:

- Ikelite housings for digital cameras with TTL conversion circuitry
- Ikelite housings for film cameras
- Nikonos V, RS cameras
- Non-Ikelite housings for digital cameras and compatible TTL adapter

Connect the strobe using an appropriate Ikelite TTL sync cord. Digital cameras require the use of a Digital TTL sync cord. These cords are designated by a blue band at one end. The DS51 may be used in TTL/auto or manual exposure modes.

TTL (thru-the-lens) exposure automatically compensates for aperture, distance and filters. Because there's such a wide range of apertures and subject distances, photographers wanting to easily balance lighting and control close-up photographer should select the TTL/auto exposure mode. When the strobe fires, the camera reads the light and signals the strobe to turn off when the exposure is correct.

Strobe output can be adjusted in TTL/auto mode using either exposure compensation built into the camera or an exposure compensation module in the back of the housing (if applicable).

If an exposure compensation module is featured in the back of the housing, strobe output may be controlled manually while the strobe itself is left in TTL/auto mode. In order to use the manual exposure modes on the strobe itself, the housing module must be set in a manual position.

When using a non-Ikelite TTL adapter or third party conversion circuitry, please refer to the product's instructions for help in using the DS51 with this setup.

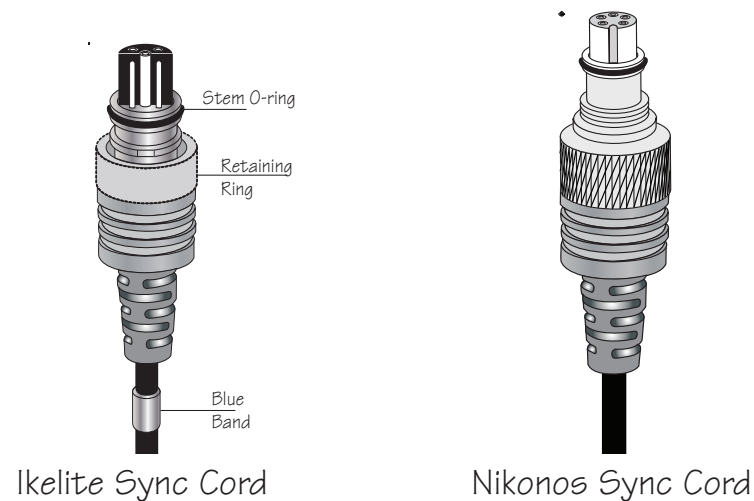

## USING AS A HARD-WIRED STROBE WITHOUT TTL

For use with the following types of systems:

- Ikelite housings for digital cameras with external strobe connector but without TTL conversion circuitry
- Non-Ikelite housings for digital cameras with Nikonos-style strobe connector

Connect the strobe using an appropriate Ikelite sync cord. The DS51 must be used in manual exposure modes. Strobe output is not automatically adjusted for proper exposure when set to TTL/auto mode.

The #4100.6 EV Manual Controller may be added in series to provide additional control of the DS51 in 10 power increments. Check with the housing or camera manufacturer to determine if the camera emits a pre-flash. Set the EV Controller selector switches accordingly for use with the DS51 (refer to the EV Controller instruction manual). Set the DS51 mode switch to "TTL/Auto" to utilize the power settings on the EV Manual Controller.

## USING AS A SLAVE STROBE

For use with the following types of systems:

- Ikelite or non-Ikelite housings without external strobe connector

The EV Manual Controller #4100.6 is required to use the DS51 as a slave strobe. The EV Controller watches the camera's built-in flash and triggers the strobe at the appropriate time.

Set the DS51 mode switch to "TTL/auto" to utilize the power settings on the EV Manual Controller. If the DS51 is set to a manual exposure mode, the power settings of the EV Manual Controller are ignored.

The camera must be set to a "force flash" mode, usually designated by a lightning bolt, in order for the DS51 to fire consistently in every photo. Both the camera's built-in flash and the DS51 must recycle completely before taking another flash photo.

Most digital cameras fire one or more short preflashes to help the camera determine focus, exposure and color balance. After the preflash(es), the camera's built-in flash fires to illuminate the subject while the photo is taken. Both the EV Manual Controller and the Substrobe DS51 are preflash compatible. The internal switches on the EV Controller must be set properly for the DS51 to fire at the correct time. Refer to the EV Manual Controller instruction manual for more information.

If the DS51 fires at the incorrect time resulting in a dark photo, the preflash setting is most likely incorrect. Check both the preflash switch on the EV Controller and the camera's exposure mode. Some digital cameras fire a preflash in Auto, Program, shutter priority and aperture priority modes, but not manual exposure modes.

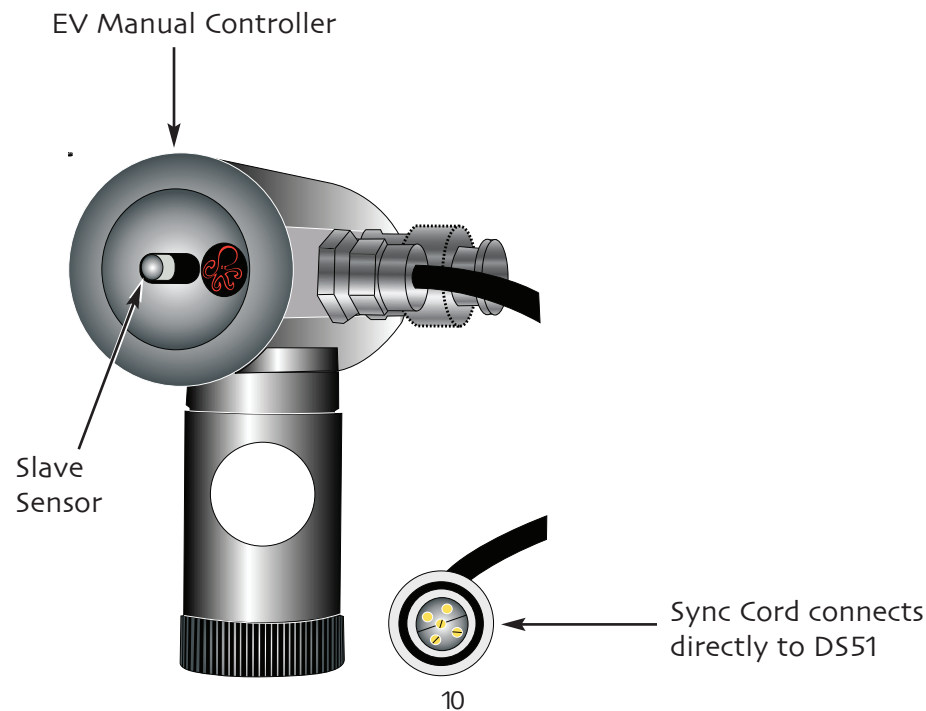

## BATTERY COMPARTMENT

### OPENING THE COMPARTMENT

Always turn the substrobe to OFF before opening the battery door located at the back of the strobe.

To access the battery compartment, rotate the knob counter-clockwise several times and gently pull the door off. Tilt the rear portion of the strobe down while removing the battery door to eliminate the possibility of water droplets falling into the battery compartment after a dive. **Do not** remove the knob from the battery door.

The battery compartment is sealed separately from the main electronics. **Do not** disassemble the strobe. Disassembly will void your Ikelite limited warranty.

### BATTERY COMPARTMENT O-RING

Be aware of the position of the o-ring around the perimeter of the battery door. Keep the o-ring and sealing surfaces clean.

Lubricant is not necessary for proper sealing of the battery door o-ring. To extend its life, you can lightly lubricate the exposed part of the door's o-ring before storing (see "Cleaning and Storage", page 18).

### CHANGING THE BATTERIES

Install four AA-cell batteries: alkaline, NiCad, or NiMH. Refer to the "+" and "-" markings in the battery compartment to help properly install the batteries. If the batteries are installed incorrectly, it may damage the strobe's electronics.

Always carry spare batteries; weak batteries cause many camera and strobe problems. It's time to replace the batteries when, after the DS51 has flashed, the ready light remains dark for 15 seconds or longer. (See "Strobe Ready Light", page 10.)

**Note:** It is possible to buy bad "new" batteries, so check the voltage output with a meter. Lithium Ion batteries are NOT recommended due to their effect on the strobe's recycle time and the batteries' thermal switch characteristics.

## BATTERY COMPARTMENT (cont.)

### CLOSING THE COMPARTMENT

Again, check that the o-ring and sealing surfaces are clean. Make sure the o-ring is back in its original position and free of any debris.

Lubricating the o-ring will NOT result in a better "seal" to the strobe and is not recommended. The o-ring is seated in the battery door channel and does not need to be removed. Frequent removal of the o-ring can increase the risk of dirt or debris getting into the o-ring channel and causing a leak. If the o-ring needs to be removed, do not use a screwdriver or other sharp instrument that may damage the o-ring channel and result in a leak.

Replace the battery door. Make sure the door fits into the recess around the battery compartment. Rotate the knob clockwise several times and firmly hand-tighten to assure the proper o-ring seal; otherwise, the battery compartment may leak. **The o-ring seal is visible through the battery door. Visually confirm that there is a solid black line which indicates a seal all the way around the door.**

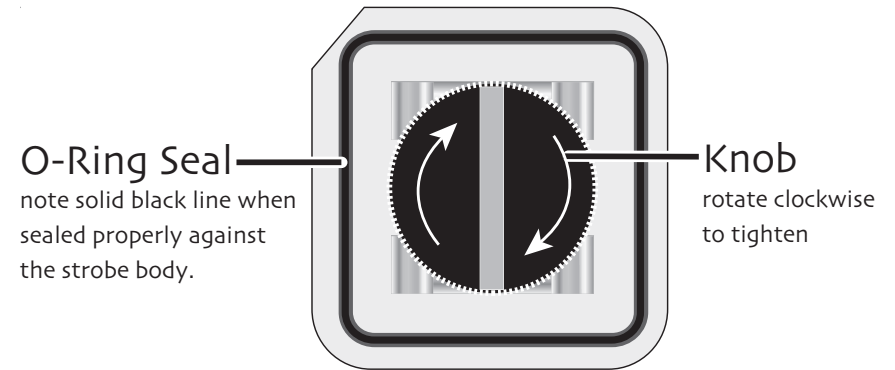

### COMPARTMENT FLOODING

The battery compartment is separate from the DS51's factory sealed electronics. Should the battery compartment flood, flush the compartment with fresh water and dry thoroughly. Determine the cause of the flooding to the best of your ability. Send the DS51 and other system components involved to Ikelite for inspection and testing as soon as possible.

Often, divers find themselves in remote locations for extended periods without access to multiple strobes. If the strobe with the flooded battery compartment is the only one available to you at the time and you're desperate to continue shooting, please follow these instructions for a temporary fix:

1. Air out and thoroughly dry the battery compartment with air from a blow dryer or a SCUBA tank hose.
2. Wash out the battery compartment with alcohol. Repeat Step 1.
3. Replace all batteries after battery compartment flooding. Never re-use batteries that have been wet. The water could create an internal short circuit in the strobe at some later date, potentially causing an explosion.
4. Reassemble with fresh batteries.
5. After returning from your trip, send the DS51 and other system components to Ikelite for inspection and testing.

# STROBE DIFFUSER

## USING THE DIFFUSER

The white diffuser can be secured to the front of the DS51 strobe when softer lighting or a coverage angle of up to 80° is desired.

The diffuser reduces the DS51's light intensity by one full f-stop.

For the TTL/auto mode example with an ISO rating of 100, if you set your camera to f-8 without the diffuser, you can shoot subjects up to 1.2m (4') away. If you add the diffuser to the strobe with the camera set at f-8 and using ISO 100, you must reference one number greater than f-8 in the chart. In this case, that number is f-11, which means you can shoot subjects up to 0.6m (2') away.

## DIFFUSER INSTALLATION AND REMOVAL

1. The white diffuser features two protruding tabs for use in installation and removal. The tabs on the diffuser should be positioned away from the strobe.
2. Place the diffuser over the front of the strobe. Spread the two tabs apart, insert the diffuser into the recessed front, and then rotate the diffuser until it locks into position.
3. To remove the diffuser, bend one tab out towards the edge while lifting simultaneously.

A lanyard or string can be attached to the diffuser by threading it through the two circular openings near its edge. Attach the other end to the strobe arm to prevent accidental loss.

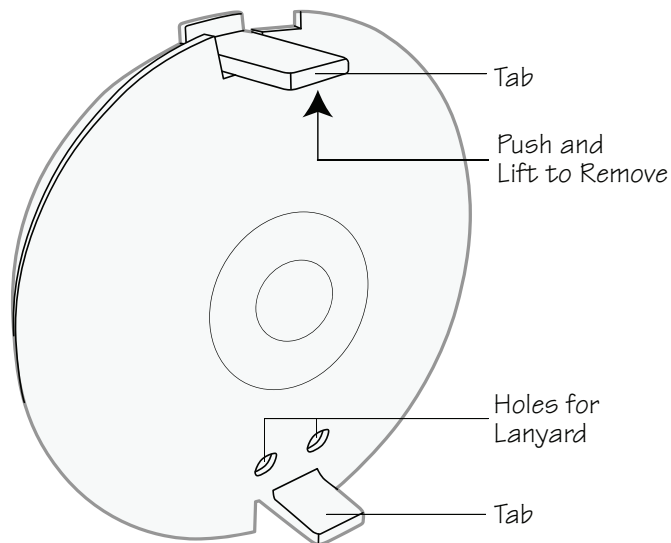

# STROBE READY LIGHT

The Ikelite DS51 Substrobe features a ready light at the rear of the strobe that glows red when the DS51 has recycled and is ready to fire its flash again. This recycling time should not exceed 15 seconds. If the glow disappears for longer than 15 seconds between flashes, it may be time for new batteries. (See "Changing the Batteries" on page 11.)

## STROBE READY LIGHT AND TTL HOUSING

When the DS51 is in TTL mode and connected to an Ikelite DSLR housing, the strobe ready light will glow green for approx. 2 seconds to indicate a correct exposure. If no green light appears, check the image for possible under-exposure. When the strobe has recycled again, the ready light will again glow red indicating that the strobe is fully powered and ready to fire. If the strobe ready light does not glow red, the batteries may be expended.

Your camera's ready light "lightning bolt" in the camera viewfinder may blink while the DS51 is recycling and then glow solid when the DS51 is fully charged. Nikon DSLRs and older Canon DSLR models such as the 20D and Rebel XT will always display a solid glow "lightning bolt" regardless of the strobe cycle.

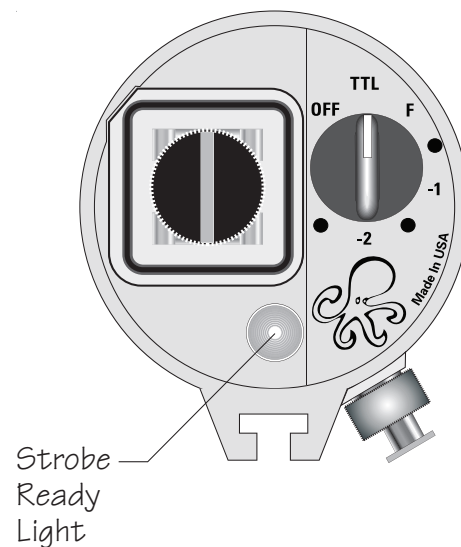

## READY LIGHT and EV MANUAL CONTROLLER

When using the DS51 strobe with the optional EV Manual Controller (page 10), without optional sync cord, the strobe is not electronically connected to the camera. Therefore, the ready light in the viewfinder of the camera indicates when the on-camera flash has recycled. Examine both the camera and strobe ready lights to make sure both flashes have fully recycled before taking the next picture.

# MODE SWITCH

The DS51 Substrobe's mode switch has eight different positions: OFF, TTL/auto exposure setting, and six manual exposure settings. Refer to illustrations on page 16.

## OFF POSITION (Refer to illustrations on page 16)

(Fig.1) Shows the mode switch in the OFF position. The white indicator on the knob aligns with OFF. Always turn the substrobe to OFF before connecting or disconnecting a sync cord or opening the battery compartment.

## TTL/AUTO EXPOSURE POSITION (Refer to illustrations on page 16)

(Fig.2) Shows the mode switch in the TTL (Thru-the-Lens) / auto exposure position. From the OFF position, rotate the switch clockwise to access the TTL/auto exposure setting; the white indicator on the knob aligns with TTL. When taking pictures with the mode switch in this position, the camera automatically signals the strobe to turn off when the exposure is correct.

- When the DS51 is connected directly to the camera, the camera must feature compatible TTL/auto exposure to utilize this mode.
- The TTL/auto firing mode must be selected when connecting the EV Manual Controller #4100.6 (page 10).

## MANUAL EXPOSURE POSITION (Refer to illustrations on page 16)

Figure 3 shows the mode switch in the manual exposure mode with the DS51 Substrobe turned to the F (full power) position. Rotate the mode switch clockwise to access the different power settings. Each power setting clockwise from F reduces the light output of the DS51 Substrobe in one-half f-stop increments. When shooting in the manual mode, it is suggested that you start the strobe at full power and adjust the camera's aperture based on the strobe-to-subject distance.

If the subject in the photo is underexposed (dark) you must move closer to the subject. If the subject is overexposed (light), then you can rotate the mode switch clockwise to reduce the light output of the strobe until the desired exposure is obtained. The DS51 provides five reductions in power in one-half f-stop increments from the full power setting. (Fig.4), for example, shows the mode switch set to -1 and 1/2 f-stops.

**Do not use manual strobe settings with a camera that emits "pre-flash". Leave the DS51 in the TTL position and adjust exposure using your camera settings or housing conversion circuitry (if applicable).**

# MODE SWITCH (illustrations)

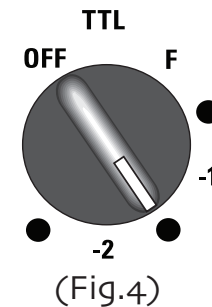
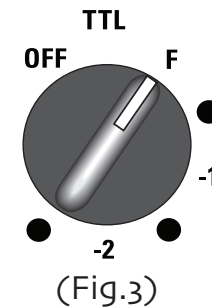
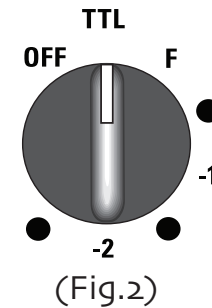
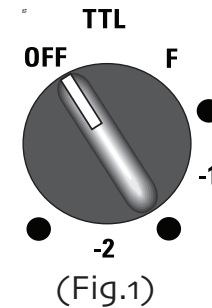
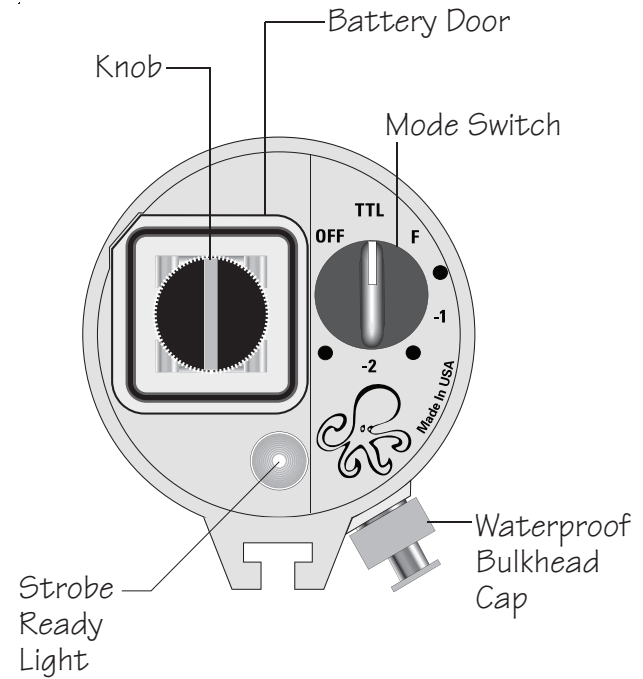

## RECOMMENDATIONS

### VISUAL INSPECTIONS

Visual inspections are important. Take the time to examine the entire assembled setup (strobe, camera housing, arms, etc.) above water. An improper seal or loose connection can cause a lot of damage. Always check for leaks once you place the equipment in the water.

### INSURANCE

It is recommended that you add an **all-risk floater** to your homeowner's and/or renter's insurance policy to cover your equipment against loss or damage. While the Ikelite DS51 Substrobe has a limited warranty against manufacturing defects, it does not cover customer neglect.

### TIPS

- Photograph through as little water as possible; move in close. Maximum recommended shooting distance underwater is 1.8m (6').
- Use the diffuser for softer lighting or a coverage angle between 70° and 80°.
- If possible, measure the light with a meter and set the camera aperture accordingly. For balanced lighting between your subject and the background, meter the available light and set the camera aperture accordingly. Using a narrower aperture darkens the background. A wider aperture lightens the background and may over-expose the photograph.
- More natural looking photos can be achieved through the addition of a second external strobe. The Ikelite EV Manual Controller #4100.6 works well with a second strobe when you plan on using manual exposure.
- Always carry spare batteries. Weak batteries are the cause of many strobe and camera problems; check the voltage with a meter. **Note:** it's possible to buy bad "new" batteries.
- **Do not** fire the strobe more than 15 times in rapid succession. If this does happen, allow the DS51 to cool off for at least 10 minutes before resuming photography.

### LUBRICANT

- Use only Ikelite brand silicone lubricant with Ikelite brand o-rings; other brand lubricants can cause the Ikelite o-rings to swell in size.
- **Do not** use spray lubricant; it can crack the plastic parts of the strobe.
- Ikelite brand silicone lubricant is provided for the sync cord stem o-ring and the bulkhead connector threads. Use only enough lubricant to lightly cover the area being applied; wipe off any excess with a clean cloth.
- Lubricant only reduces friction; it is not a sealant.

## MAINTENANCE

Your Ikelite DS51 Substrobe should be given the same care and attention as your other photographic equipment. After using your strobe in water, please follow these instructions to insure the DS51's longevity and good working order.

### CLEANING AND STORAGE

**Caution:** Make sure the DS51's battery door is on and tightened down before exposing the strobe to water. Ideally, water should never enter the battery compartment. If this does occur, see "Compartment Flooding" on page 12.

1. Always rinse the exterior of the DS51 with fresh water after use, especially after exposure to salt water. While rinsing, turn the mode switch to free salt or debris that might have accumulated in the DS51's recesses during the dive.
2. Dry the DS51 thoroughly.
3. Check the battery door's o-ring and sealing surfaces for any debris and gently wipe it away with a soft, lint free cloth. Lightly lubricate the exposed part of the door's o-ring.
4. Check the DS51's bulkhead connector threads for debris. Gently wipe away with a soft, lint free cloth or a cotton swab to clean the threads. Afterwards, lightly lubricate them.
5. Remove the batteries and store the DS51 with the battery door lightly screwed on; this will allow any hydrogen/air mixture to escape the battery compartment and avoid placing unnecessary pressure on the o-ring that could cause it to flatten.

In addition to these procedures, it is strongly recommended that this strobe be returned to Ikelite periodically for inspection and water pressure testing. Ideally your DS51 should undergo this process every two years or 100 dives, whichever comes first.

# TROUBLESHOOTING

## STROBE WILL NOT FIRE

1. Check the DS51's ready light. Turn the strobe's mode switch to OFF and then back to TTL. Make sure that the switch has actually clicked into position.
2. Check that the batteries are inserted according to the "+" and "-" markings. It is possible to buy bad "new" batteries, so check the voltage output with a meter if possible. If using NiCad or NiMH batteries, make sure the charger is operating properly and that the batteries are fully charged.
3. Check the mode switches on the camera and strobe.
4. Check the cord connections at the camera and strobe.
5. When using a sync cord between the camera and strobe, disconnect the cord from the camera but leave the cord connected to the strobe. Then use the two ends of a bent paper clip to connect different receptacles on the flash cord contacts, as detailed in the diagram below. This process, known also as "shorting," creates a temporary circuit that can test-fire the strobe.

**Caution:** When creating a circuit via paper clip, or "shorting," pay close attention to which two receptacles you connect. If you short across the wrong receptacles on a TTL sync cord, you may damage the DS51's electronics.

The specific receptacles to connect with the paper clip vary based on the type of cord you own. Please refer to the diagram of two types of flash cord contacts.

### Ikelite Sync Cord

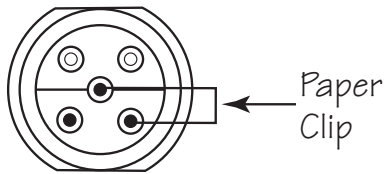

### Nikonos Sync Cord

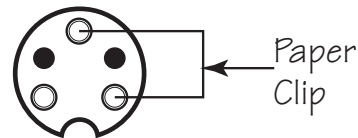

**Ikelite TTL Cord:** Point the raised half-circle at the end of the cord encompassing the receptacles towards you, per the above diagram. Place one end of the paper clip on the center receptacle and one end on the lower right-hand receptacle. The DS51 should flash.

**Nikonos TTL Cord:** Point the indexing groove at the end of the cord towards you, per the above diagram. Place one end of the paper clip on the top-most, center receptacle and one end on the lower, right-hand receptacle. The DS51 should flash.

If the DS51 flashes, the source of the problem lies somewhere in the camera. If the DS51 does not flash, please send both the strobe and cord used in the test to an authorized Ikelite dealer or to Ikelite; see "Returning Products for Service" on page 20.

**Do not** attempt to repair the strobe or cord yourself. This may cause further damage and void your Ikelite limited warranty.

# WARRANTY SERVICE

## IKELITE LIMITED WARRANTY

Ikelite Substrobes are warranted against any manufacturing defects for a period of two years from the original date of purchase. All other Ikelite products are warranted against any manufacturing defects for a period of one year from the original date of purchase. Defective products should be returned prepaid to Ikelite. Ikelite will, at its discretion, repair or replace such products, and will return them to the customer prepaid. All other claims, of any nature, including, but not limited to bulb failure, are not covered. Except as mentioned above, no other warranty, expressed or implied, applies to this Ikelite product.

## RETURNING PRODUCTS FOR SERVICE

Ikelite is most interested in performing any service to assure that all products perform as intended. For repair service, return the Ikelite product to the address below with your name, address, phone number, and a brief description of the problem. Evidence of purchase date must be provided to obtain warranty service. Thank you.

### IKELITE UNDERWATER SYSTEMS

50 West 33rd Street  
Indianapolis, IN 46208 USA

317-923-4523

[www.ikelite.com](http://www.ikelite.com)

Email: [ikelite@ikelite.com](mailto:ikelite@ikelite.com)