

Ikelite Digital Housing

instruction manual
#6140.05 for Canon PowerShot S5 IS



Congratulations on your purchase of an Ikelite Digital Camera Housing. Ikelite has over 30 years of experience in the underwater photographic and lighting market. Our products are designed and built in the USA by Ikelite for both the professional and amateur photographer.

The clear housing permits instant visual inspection of the camera and all sealing surfaces as well as complete monitoring of controls and camera LCD screens.

Ikelite Digital Housings are slightly negative in salt water for stability. This housing has been water pressure tested at the factory. Housing is pressure tested to 200' (60m).

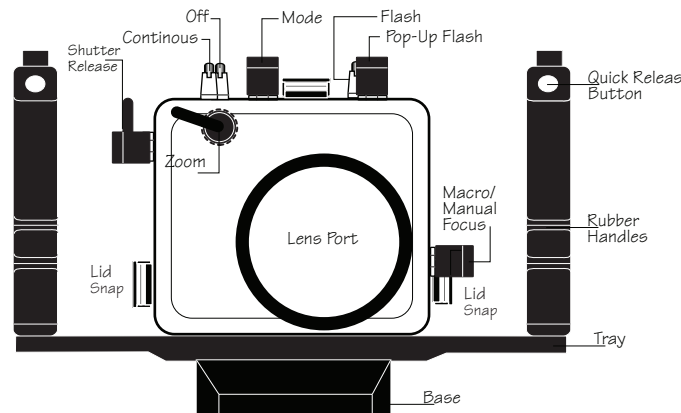

FRONT VIEW

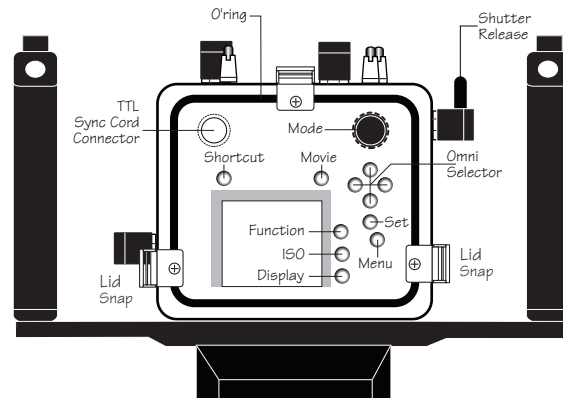

BACK VIEW 2

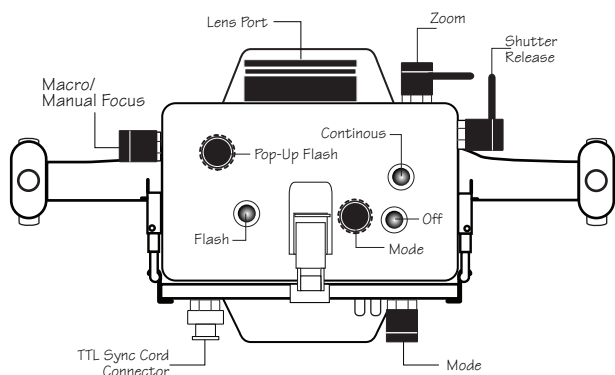

TOP VIEW

Opening the Housing

1. Lid Snaps have a Lock.

To open, push Lid Snap Lock forward and lift as shown. Keep pressure on the Lid Snap so it does not fly open quickly.

Some lid snaps have a lot of spring tension once they go over center, have a firm grip on the lid snap. Lid Snaps may be opened one at a time.

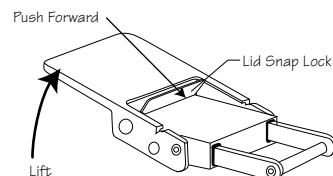

Installing the Camera

1. Remove the back from the housing. The mounting tray for the camera is secured to the housing back. Position the camera on the tray and secure it with the mounting bolt which threads into the camera's tripod socket. **Use a coin or flat bladed screwdriver to tighten the mounting bolt so the camera is flat against the tray.**

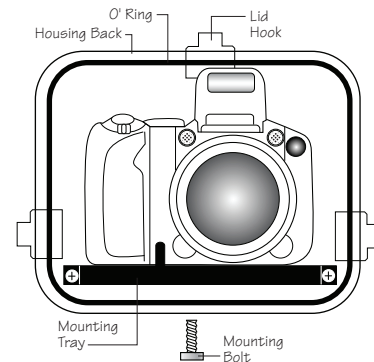

CAUTION:

Some camera tripod socket threads are plastic. The mounting tray bolt is metal. Do not cross thread or over tighten as you may damage the camera tripod socket threads.

2. Pull out on each housing control until it stops. This will get the controls out of the way for installing the camera.

Flash Connection for External Strobes

When using an external strobe connect the housings Hot Shoe Connector. Slide the connector into the hot shoe of the camera from the back of the camera as shown. Slide the connector forward until it stops. This should be done before the camera is secured with the mounting bolt.

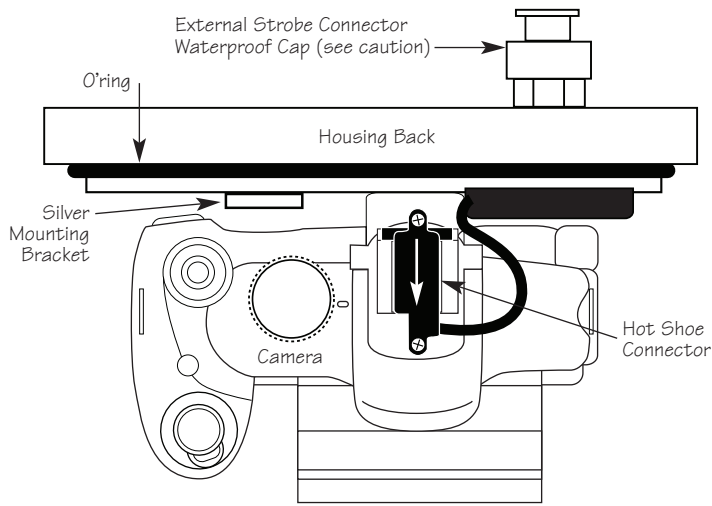

Caution:
Do not remove the External Strobe Connector's waterproof cap unless an external sync cord is going to be plugged in.

5

Closing the Housing

1. Place housing face down in your lap or on a flat surface.
2. Check to see that there is an o'ring on the housing back and that it is clean and in its proper location.
3. Guide the back onto the housing. The o'ring should touch the housing all the way around. There should be an even gap all the way around between the housing and the housing back.
4. Lift the lid snaps so they are extended and place the lid snap into the hook on the housing back.
5. To close the housing push down on the lid snaps until they snap into place. Lid snaps on opposite sides of the housing should be closed at the same time. Be sure they are down far enough to engage the lock.

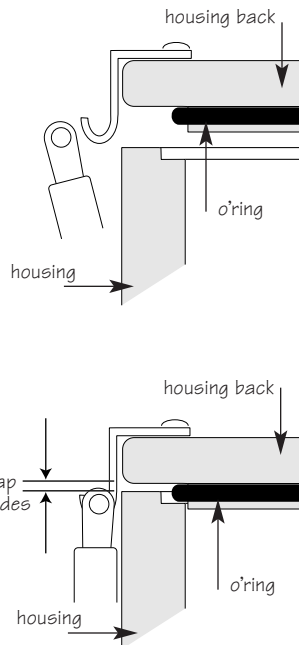

Double check - Once the housing is closed, check the o'ring seal. Check the gap between the housing back and the housing, it should be even all the way around.

Look through the clear plastic back at the o'ring. You should see a darkened area where the o'ring is compressed against the housing back. If you do not see an even black compression seal all the way around the back, open the lid snaps, reseal the housing back and close the lid snaps. Visually check the seal again.

7

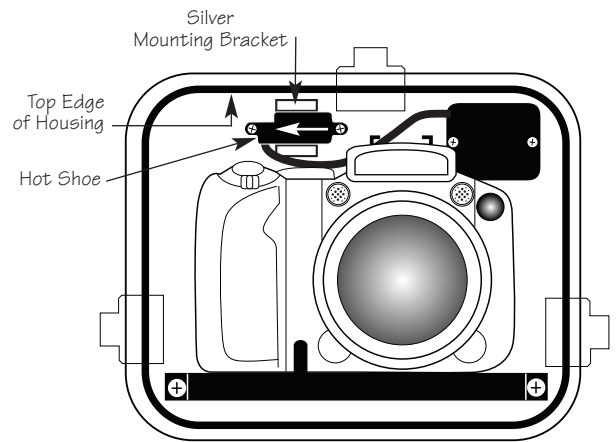

If you are not using the External Flash Connection

Store the hot-shoe by sliding it into the silver bracket located on the inside back of the camera housing as shown. This can be done after the camera is mounted to the mounting tray.

CAUTION

Only remove the WaterProof cap from the external strobe connector on the back of the housing when an external strobe will be connected.

6

Checking Controls

Once the housing has been closed, push the controls back into place. Make sure they line up with the camera's controls.

Turn Camera On

Turn the camera on and operate each of the housing controls to get a feel for using the camera in the housing. Take a few pictures above water with the camera in the housing.

Zoom Control

(NOTE:) After you have used the housing's zoom control it must be returned to the center position to disengage. If the housing zoom control is pushing the zoom lever in either direction you may not be able to take a picture or access any other function as the camera is receiving a signal from the engaged zoom control.

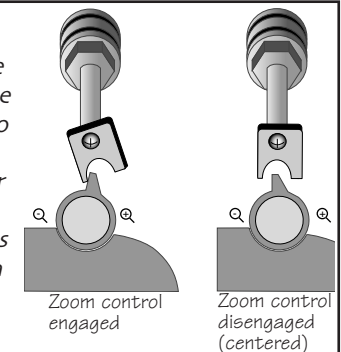

Lubricants

1. Ikelite provides silicone lubricant with the housing. We recommend you use only Ikelite lubricant on Ikelite products as some other brands may cause the o'ring to swell and not seal properly.
2. Use only enough lubricant to lightly cover control shafts and o'rings. Wipe off any excess lubricant with a clean cloth. Lubricant is not a sealant, it is used to reduce friction. Excessive lubricant can collect sand and dirt which may interfere with proper sealing.

CAUTION

Never use spray lubricants as the propellant ingredient can cause the plastic housing to crack.

8

Lens Port

The Lens Port is factory sealed, do not remove. Treat the glass in the lens port as a camera lens. After use, rinse and gently dry the lens port to avoid water spotting. To clean use a mild soap solution or lens cleaner.

Do not use alcohol or window cleaner on the Lens Port.

The Lens Port is threaded so that accessory lenses can be screwed onto the port. The threads are very fine, take care not to cross thread accessory lenses.

The housing port has a 67mm thread which accepts the optional #6420 Ikelite W-20 Wide-Angle Lens and other manufacturers (67mm) screw thread style lenses. These lenses can be screwed onto the lens port above or below water. These lenses are designed to have water between the front of the port and the accessory lens. Make sure no air bubbles are trapped between the port and the accessory lens. There may be slight vignetting when these wide angle lenses are installed. Any vignetting that occurs can be eliminated by zooming the camera lens slightly. To properly light subjects when using a wide angle lens an external strobe should be used. Due to the wide coverage of the wide angle lenses, the DS125 Substrobe is recommended or two DS51 Substrobes.



Housing shown with accessory wide angle lens.

9

Diffuser and Deflector cont.

A diffuser and deflector are included with the housing. The diffuser is white transparent plastic. The deflector is also white but is not transparent.

To install the diffuser or deflector spread the port clamp at the spring end and slide over the lens port. The white plastic should be placed in front of the camera flash. The port clamp should be pushed back against the front of the housing.

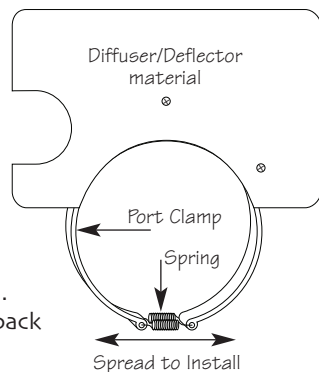

Diffuser

The diffuser should be installed when using the camera's built in flash. When shooting with the camera's built-in flash at approximately 2 feet (0.6 m) or less, zoom the lens to maximum telephoto. The lens port on the housing blocks a portion of the light from the camera's built-in flash when shooting close up. If you do not zoom to maximum telephoto, a shadow may appear in the lower left corner of close-up photographs. *(You can test this above water)*

Deflector

The deflector should be installed when using an external strobe such as the DS51 or DS125 Substrobe and DS Sensor. The deflector is required when using the camera's built-in flash to trigger the EV Controller. The deflector will redirect the camera's flash to the DS Sensor or EV Controller which controls the external strobe.

11

Using Flash

Using the Camera's Built-in Flash.

If you do not have an external flash the camera's built-in flash can be used. See Diffuser instructions.

Diffuser & Deflector Installation



Housing shown with diffuser installed.

10

Using External Strobes

Using TTL Flash Exposure with External Ikelite DS Substrobes (Recommended)

This housing has Conversion Circuitry built into the housing. When used with current model Ikelite DS Substrobes the Conversion Circuitry provides Canon eTTL flash exposure. In the TTL mode the camera controls the light output of the external strobe(s) to obtain properly exposed images. The Conversion Circuitry is powered by the Ikelite DS Substrobe when connected to the housing with the #4103.51 single or #4103.52 dual sync cords with a blue band. See page 13 for DS Substrobe compatibility with Conversion Circuitry.

Using Manual Exposure with External DS Substrobes

Any Ikelite DS Substrobe(s) can be used in the manual mode when connected with the #4103.51 single or #4103.52 dual sync cord with a blue band. In the manual mode different power settings on the DS Substrobe can be selected to obtain a properly exposed image.

Using Ikelite Non-DS Substrobes (Substrobes 50, 100A, 200, 400) with this housing.

The Conversion Circuitry is automatically disabled when used with a Non-DS Substrobe. These Substrobes can be used in their manual mode utilizing any power settings provided on the Substrobe.

Using Non Ikelite Strobes with this Housing

The Conversion Circuitry is automatically disabled when used with a Non Ikelite strobe. These strobes can be used in their manual mode utilizing any power settings provided on the strobe.

12

NOTE: DS Substrobe Up-date may be required.

DS50 Substrobes

- DS50 SubStrobes with a Serial Number below 63,850 can not be updated to operate with the Conversion Circuitry.
- DS50 SubStrobes with a Serial Number between 63,850 and 69,999 operate with the Conversion Circuitry, but require update to provide optimum performance.
- DS50 Substrobe with a Serial Number of 70,000 or higher or with one of the two following labels in the battery compartment provide optimum performance with the Conversion Circuitry.

DS125 Substrobes

- DS125 Substrobes with a Serial Number below 2,500 must be updated to operate correctly with the Conversion Circuitry.
- DS125 Substrobes with a Serial Number between 2,501 and 4,900 operate with the Conversion Circuitry but require update to provide optimum performance.
- DS125 Substrobe with a Serial Number of 5,000 or higher or with one of the two following labels in the battery compartment provide optimum performance with the Conversion Circuitry.

For Substrobe Up-Date:

Contact Ikelite for information.



13

Optional Accessories

Substrobe DS51 Packages

Package #3944.45

Includes:
DS51 Digital Substrobe
Ikelite TTL Sync Cord
Strobe Arm Is #4075.1

Package #3944.51

Includes:
DS51 Digital Substrobe
Ikelite TTL Sync Cord
Strobe Arm #4086.61 (ball socket arm)

The DS51 Digital Substrobe is equally suited for general and wide-angle photography, covering up to 80° with the diffuser. Powered by four AA-size batteries, the compact size of the DS51 makes it ideal for macro photography.



Ikelite Photocase

Waterproof equipment carrying case featuring die-cut foam openings to accommodate the camera housing, strobes, mounting arms, etc.

Photocase #3940.4 with die-cut foam.

14

Optional Accessories, cont.

Substrobe DS125 Packages

Package #3944.75

Includes:
DS125 Digital Substrobe
1.5-hour Smart Charger 110/240V
Ikelite TTL Sync Cord
Strobe Arm #4086.61 (ball socket arm)

The Ikelite DS125 digital Substrobe combines high intensity output and wide 100° angle of coverage with the diffuser, in a compact, versatile design. The easily interchangeable and rechargeable NiMH battery pack recycles in 1.0 second. Built-in modeling light / night diving light.

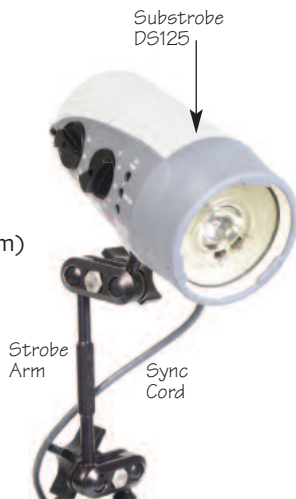

15

Optional Accessories

Back O'ring #0132.59

O'rings last for several years if properly maintained. (See maintenance) Always carry a spare.

UR/Pro Filter (Blue Water) #6441.41

The UR/Pro underwater color correcting filter is designed to restore some of the warm colors filtered out by the water. For available light use only, not recommended for use with flash.

Green Water Filter #6441.81

Enhances contrast and alters the color of green water to give our subject a rich, natural tone. For available light only, not recommended for use with flash.

Use the EV Controller with a DS Substrobe

The EV Controller provides 10 manual power settings in 1/2 stop increments for the DS51 or DS125 Substrobes. The EV Controller has a built-in slave which can be triggered by the camera's built-in flash.

Ikelite W-20 Wide-Angle Lens #6420

Wide-Angle lenses allow you to capture more of the scene and get closer to your subject which results in clearer images and more vivid color. Can be installed or removed underwater for maximum versatility. (Note: some housings may require an adapter, see instructions.)

Substrobe Packages available

Ikelite Ball Arm Systems are provided with these packages
#3944.45 SubStrobe DS51 with Sync Cord & Strobe Arm
#3944.51 SubStrobe DS51 with Sync Cord & Ball Socket Arm
#3944.75 SubStrobe DS125 with Sync Cord & Ball Socket Arm

16

Maintenance

The Ikelite Digital Housing should be given the same care and attention as your other photographic equipment. In addition to normal maintenance we recommend that the housing be returned to Ikelite periodically to be checked and pressure tested.

1. **Do Not** leave the camera and housing in direct sunlight for prolonged periods. Heat may damage the camera.
2. **Do Not** ship the camera in the housing.
3. Before using the housing, always check the tightness of the **set screw** in each control knob.
Check each **control gland** to make sure they are tight. There is a slight chance that either could vibrate loose during travel.
4. Keep the back o'ring clean and lightly lubricated. To lubricate remove the o'ring from the back. Put a small amount of Ikelite lubricant on your fingers. Draw the o'ring through your fingers to apply a light coating of lubricant. Only apply enough lubricant to make the o'ring feel slick. **Do Not stretch the o'ring.** This light coating of lubricant will help to keep the o'ring from drying out and will help to show a dark sealing line when the housing back is properly sealed.
5. Keep the area where the o'ring fits and the sealing surface of the housing clean.
6. Rinse the housing exterior in fresh water after each salt water use. Dry with a soft cloth. Dry lens port to eliminate spotting. After several uses in salt water soak the housing in a mild soap solution, rinse and dry before storage. When storing the housing, remove the back o'ring, lightly lubricate and place in a plastic bag. Place the plastic bag with o'ring inside the housing for safe keeping.

CAUTION

Never use spray lubricants as the propellant ingredient can cause the plastic housing to crack.

17

3. Some of the controls have a short shaft and cannot be pulled out exposing the shaft for lubrication. In the unlikely event one of these controls sticks or becomes difficult to operate you can remove the control from the housing and lubricate it, or return the housing to Ikelite for maintenance. To remove the control, loosen the set screw in the knob (allen wrench required); remove the knob. If there is salt or dirt build-up on the exposed control shaft, clean the shaft. Open the housing and gently slide the control shaft out of the control gland. Clean and lightly lubricate the shaft, including the end of the shaft. Slide the shaft back into the control gland and gently slide it back and forth a few times without fully removing the shaft from the gland. Replace the knob, NOTE the flat area on the shaft, the set screw in the knob should tighten down against the flat area on the control so the knob does not turn on the shaft.

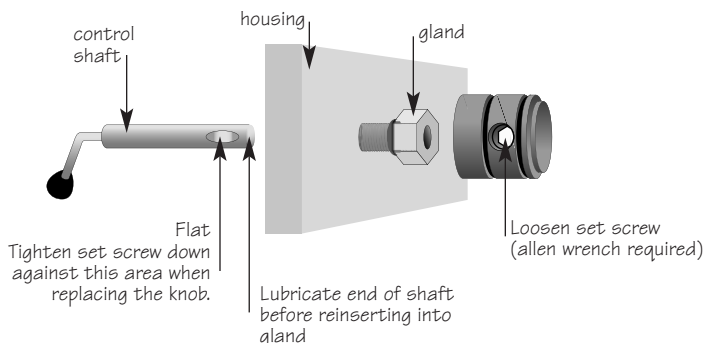

19

Control Maintenance

Ikelite controls are designed to provide years of reliable service with minimal maintenance.

1. Push button controls require no maintenance other than rinsing in fresh water after saltwater use. If a push button control becomes difficult to push or if it sticks when depressed, soak the housing in luke warm fresh water. After a few minutes operate the push button. If this does not correct the problem, return the housing to Ikelite for maintenance.
2. Some of the controls have long shafts. These controls can be

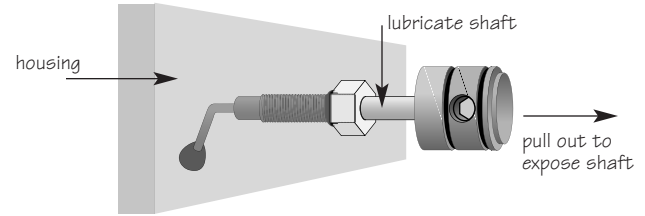

pulled out, exposing the shaft (see drawing).

To lubricate the control, gently pull on the knob until the stainless steel shaft is exposed. Lightly lubricate the shaft, then move the shaft in and out several times. This will lubricate the x'ring in the Ikelite control gland. This should be done before using the housing after a prolonged storage period, or once a week when the housing is in use.

18

General Tips

1. Due to the power required to operate the camera, flash, and LCD screen it is a good idea to start each dive with a fresh set of batteries.
2. Some cameras reset their flash to AUTO when the camera is turned on. If you prefer another setting be sure to select it.
3. As soon as you enter the water, take a moment and check the housing to see that it is properly sealed.
4. Next, check to see if there are any bubbles on the face of the lens port. If there are, take your finger and remove them. If there are bubbles on the lens port they can produce soft focus spots in your photographs.
5. If you use the housing Zoom control, make sure to move it back to the center position. If the housing Zoom control is pushing the camera zoom lever to either side the camera will not function.

Photo Tips

1. The number one rule in underwater photography is eliminate as much water between camera and subject as possible. Get as close as you can to the subject, then use the zoom. If you are using flash, subjects beyond 6 feet (1.8m) will not have much color.
2. Digital cameras have a slight lag time between when you press the shutter release button and the camera actually takes the picture. Hold the camera steady a second or two after pressing the shutter release button.
3. Do not shoot down on subjects as they will quite often blend into the background and be difficult to see in the photograph. Shoot subjects straight on or shoot up at a slight angle using the blue water as a contrasting background.

20

